



# Spray Paver

## Operator's Manual



Operation • Maintenance • Troubleshooting

©2020 Integral dx. All rights reserved.

08.20.2020 Rev G

[www.integraldx.com](http://www.integraldx.com)



# Table of Contents

<b>Introduction</b> .....	<b>7</b>
Thank you!.....	7
Limited warranty .....	8
Claim Administration Policy Procedures .....	8
Indemnity.....	10
Product Improvement Liability Disclaimer .....	10
Safety.....	11
Safety alerts.....	11
Damage warning, notes and tips.....	12
General safety rules.....	13
Safety decals.....	15
<b>General description</b> .....	<b>18</b>
General specifications .....	20
Components .....	21
Emulsion tank group.....	22
Pump group .....	24
Emulsion spray group .....	26
Hydraulic system .....	41
Pneumatic system .....	41
Emulsion tank heating system.....	43
Control system.....	48
<b>Installation</b> .....	<b>58</b>
System delivery and inspection.....	58
Machine setup.....	58
<b>Operation</b> .....	<b>59</b>
Pre-operating precautions .....	59
Operating precautions .....	60
Fire and explosion precautions .....	61
Hydraulic system precautions .....	62
Using the display screen unit .....	63
Start screen.....	60
Display navigation .....	61

Sprayer selection screen .....	62
Pump function screen .....	68
Spray bar vacuum screen .....	71
Totals screen.....	72
Camera screens (1 and 2) .....	70
Password screen .....	71
Service screen.....	72
System Data Screen.....	73
Troubleshoot Sequence.....	74
Auto-Nozzle Option .....	79
Alarms screen .....	81
Spray paving steps.....	84
Loading emulsion in the tank(s) .....	88
Circulating the tank .....	90
Circulating the spray bar .....	91
Spraying emulsion .....	92
Vacuuming back emulsion.....	94
Cleaning out and rinsing.....	95
<b>Maintenance .....</b>	<b>102</b>
Recommended spare parts .....	102
Service interval.....	103
Routine maintenance procedures.....	100
Cleaning the spray wand .....	102
Cleaning the machine .....	102
Cleaning the strainer screen in the pumping station .....	107
Checking the hydraulic oil level.....	108
Inspecting hydraulic hoses and emulsion hoses .....	108
Checking the fluid level in the clean out tank .....	108
Cleaning blockage from the emulsion tank overflow tubes .....	108
Cleaning the hydraulic cylinder rods .....	109
Draining the air compressor tank and air filter .....	109
Draining the emulsion tank sump .....	110
Inspecting the packing gland on the emulsion pumps.....	110
Inspecting the emulsion pump coupler.....	111

Lubricating the emulsion pump bearings.....	111
Inspecting the packing gland on the emulsion tank.....	111
Checking the tightness of the tank tie-down hardware.....	111
Checking spray nozzle alignment .....	111
Checking the spray bar hardware.....	111
Checking the condition of the hydraulic filter.....	112
Removing debris in the emulsion tank sump.....	112
Checking oil in the compressed air oiler .....	112
Changing the hydraulic oil and filter .....	113
Changing the fluid in the clean out tank .....	113
Replacing the engine air filter element. ....	113
Calibrating the small asphalt pump.....	113
Storage .....	116
Startup after storage .....	117
Hydraulics system check.....	117
Cleaning agent check.....	117
Function check.....	118
<b>Troubleshooting.....</b>	<b>121</b>
Cleaning the emulsion tank.....	125
Cleaning a stuck pump .....	129
Setting the small emulsion pump bypass pressure.....	132
<b>Appendices .....</b>	<b>133</b>
Appendix 1: Valve and emulsion pump configurations for the pump functions.....	134
Appendix 2: Pump group flow paths.....	136
Tank load .....	136
Tank circulate .....	137
Spray bar circulate.....	138
Spray auto.....	139
Spray bar vacuum .....	140
Clean out.....	141
Bypass setting.....	142
Appendix 2: Updating PLC and display software .....	143
Downloading and running the software .....	143

Programming the display screen unit .....	144
Programming the control unit.....	147
Appendix 3: Maintenance record.....	150
Appendix 4: Emulsion tank configuration .....	151

# Introduction

## Thank you!

Thank you for choosing the Integral dx spray paver.

The spray paver is an accessory for an asphalt paving machine that applies emulsified asphalts (emulsion) to surfaces before paving. The spray paver sprays emulsion uniformly, at specified application rates, and without the paver wheels or tracks running over the applied emulsion.

The spray paver is designed and manufactured in the USA with quality materials and workmanship. With proper use and care, it will provide you many years of trouble-free service.

Keep this manual handy for frequent reference, and to pass onto new operators or owners. Contact Integral dx if you need assistance, further information or additional copies of the manuals.

The information in this operator's manual is in effect at time of printing. It is subject to change without notice. Configurations of specific models may vary.

## Limited Warranty

Integral dx warrants products of its manufacture, when used correctly under normal operating conditions, to be free of defects in materials and workmanship. Integral dx makes no other warranty expressed or implied. This warranty shall be for a period of 6 months from the date the product is put into service, provided Integral dx is supplied with the in-service date. The warranty shall not apply to any products that have been altered, changed, or repaired in any manner whatsoever, except by an authorized Integral dx repair facility; nor to any product which has been subject to misuse, negligence, or accident. The exclusive and sole remedy for breach of contract shall be limited to repair, modification, or replacement at the sole discretion of Integral dx. Integral dx shall not in any event be liable for the cost of any special, direct or consequential damages. Integral dx reserves the right to make changes or improvements in the design or construction of any part without incurring the obligation to install such changes on any previously delivered products.

### Claim Administration Policy Procedures

Integral dx must be **contacted immediately** for authorization to proceed when a warranty problem is suspected. If parts need to be replaced, please ask for a Return Goods Authorization (RGA) number at this time.

Hydraulic components (i.e. pumps, motors, planetary drives, and valves) are not to be disassembled when performing possible warranty work.

**Unauthorized disassembly of these components will void warranty.**

A Returned Goods Authorization (RGA) number must be obtained and the defective parts returned immediately with the RGA number marked on the parts and the shipping containers before any warranty consideration can be determined. Return these components prepaid via common carrier or UPS ground to Integral dx for examination.



Warranty will not be allowed against failure due to the following:

- Normal wear and tear
- Abuse or accident
- Modification of original equipment
- Improper service or maintenance
- Improper installation
- Contamination

Labor will be credited at 75% of the authorized providers published labor rate, **travel time not included.**

Travel to and from job sites will be covered at \$0.50 per mile and not to exceed a 100 mile round trip.

Before warranty claims will be paid, Integral dx will need to have on file the In-Service Report.

Overnight or other special freight charges will not be covered under warranty.

All claims must be submitted within 30 days of service on an Integral dx claim form with the authorized providers work order attached.

All repair part orders will require a purchase order and will be billed at a normal rate. Credit will be issued when warranty is approved.

Original Equipment Manufacturer (OEM) parts will be warranted according to the OEM warranty upon shipment date of product.

## **Indemnity**

Buyer agrees to indemnify and hold Integral dx harmless for all loss, cost including but not limited to legal and other cost of proceedings, and damages suffered by Buyer or claimed by third parties by or related to Buyer's use of Integral dx products.

## **Product Improvement Liability Disclaimer**

Integral dx reserves the right to make any changes in or improvements to its products without incurring any liability or obligation whatsoever and without being required to make any corresponding changes or improvements to products previously manufactured or sold.

THIS WARRANTY IS IN LIEU OF ALL OTHER WARRANTIES EXPRESSED OR IMPLIED INCLUDING ANY IMPLIED WARRANTIES OF MERCHANTABILITY OR FITNESS FOR A PARTICULAR PURPOSE, WHICH ARE HEREBY DISCLAIMED AND OF ANY OTHER OBLIGATION OR LIABILITY OF INTEGRAL DX. THE REMEDY SET FORTH ABOVE IS BUYER'S EXCLUSIVE REMEDY FOR A BREACH OF THE WARRANTY.

UNDER NO CIRCUMSTANCES WILL INTEGRAL DX BE RESPONSIBLE FOR INCIDENTAL, CONSEQUENTIAL, SPECIAL OR OTHER INDIRECT DAMAGE.

# Safety

How you operate and maintain your equipment directly affects your safety and the safety of others. Therefore, read and understand this manual and any other safety information provided, including safety decals on the equipment.

Integral dx cannot anticipate every possible circumstance that may involve a potential hazard. The safety alerts in this manual are therefore not all inclusive. If you use an operating procedure, installation or work method not specifically recommended, you must be sure that it is safe for you and for other persons. You must also ensure that the product will not be damaged or made unsafe by the procedure that you use.

## Safety alerts

Safety alert symbols in this manual or on the machine indicate important messages regarding safety. When you see the safety alert symbol and the signal word after, carefully read the message that follows and understand there is a possibility of injury or death if you do not adhere to the requirements of the safety message.



**Danger:** Indicates a hazardous situation that, if not avoided, will likely result in death or serious injury.



**Warning:** Indicates a hazardous situation that, if not avoided, could result in death or serious injury.



**Caution:** Indicates a hazardous situation that, if not followed, could result in minor or moderate injury.

### Damage warning, notes and tips



**Avoid damage:** Indicates a situation that could cause damage to the spray paver or property damage.



**Note:** A note contains information that is important for operating or maintaining the spray paver.



**Tip:** A tip contains useful information that can improve or optimize use of the spray paver.

## General safety rules

The general safety rules are included in this section of the manual. Specific safety rules will appear throughout the manual.



**Danger:** Before operating or servicing this equipment, complete proper training. Also read and fully understand the operator's manual and the safety labels on the machine.



**Danger:** Do not smoke around the machine. Fuel, emulsion, and fumes can explode when exposed to flames or heat from smoking or other sources.



**Warning:** Have a first-aid kit available and know how to use it.



**Warning:** Keep a charged fire extinguisher within reach whenever you work in an area where fire may occur.



**Warning:** Wear safe work clothing, which includes rough-soled work shoes, safety glasses and any other protective gear that is warranted by the work environment. Do not wear clothing that is loose fitting or in poor repair when working on machinery. Do not wear rings, wristwatches, or other jewelry while working on machinery. They can catch moving parts and pull you into the machinery, causing serious injury or death.



**Warning:** Stop operation and investigate anything that does not look or feel right.



**Danger:** Asphalt emulsion is a water-base product. As such it will boil at 212°F (100°C), causing steam inside pipes, which can result in an explosion.



**Warning:** When hot emulsion touches your skin, flush the affected area immediately with cold water. Do not apply ice directly to the affected area. Do not attempt to remove emulsion with products containing solvents or ammonia. Natural separation will occur in about 48 to 72 hours. Get medical attention as soon as possible.

## Safety decals

The Integral dx Spray Paver is equipped with a number of safety decals indicating hazards to be avoided when operating the spray paver.

Understand the decals before using the spray paver:



Hot material is present. Take care to avoid contact with it during spray paver operations.



Moving parts could pinch a hand, foot, etc. Take care to not get body parts trapped between the parts.



An electrical hazard exists that could potentially provide a serious shock. Avoid the hazard during operation.



Hot pipes are present that could provide serious burns to exposed skin. Avoid contact with them.



Ensure covers are in place for safe operation of the spray paver.



The operator cannot see this part of the machine. Stay away during operation.



Do not disconnect lines. Doing so during spray paver operation will cause death or serious injury.



Spray bars may be damaged by low ground clearance. Always tilt and pin the spray bar assembly up when not spraying emulsion.

### Safety decal location

Note the location of each of the safety decals on the Integral dx spray paver (see **Figure 1**).

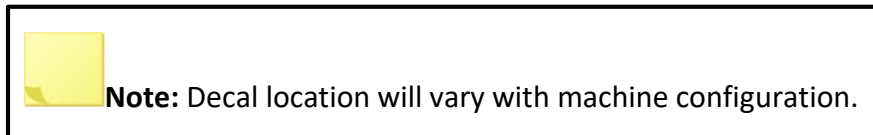

Safety decals must be present, in good condition, and in the specified locations at all times.

- If any decals are missing or damaged, replace them before operating the spray paver.
- When replacing parts that previously displayed a safety decal, be sure to replace the decal as well.
- Instructions for replacing worn or missing decals are provided below.



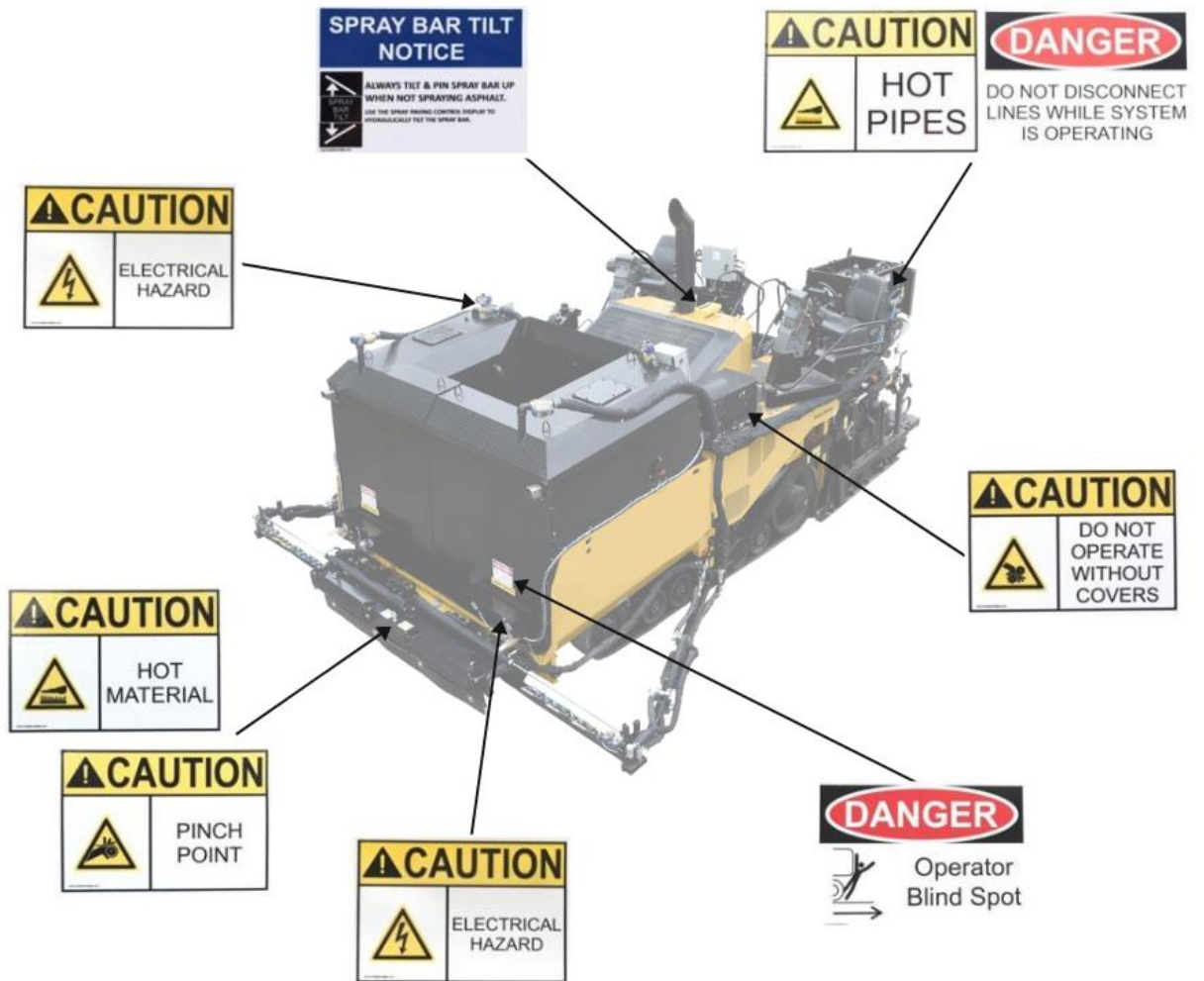

**Figure 1:** Safety decal location (may vary depending upon model)

## Safety decal replacement



**Warning:** Do not operate the spray paver until the safety labels are in place.

Replace safety decals as follows:

1. Be sure that the installation area is clean and dry. Use hot soapy water, then dry the application area thoroughly.
2. Decide on the exact decal position by taking measurements and test fitting before you remove any of the backing paper.
3. Remove part of the adhesive backing.
4. Align the decal over the specified area, and carefully press the exposed adhesive backing into place.
5. Slowly peel back the remaining adhesive backing, carefully smoothing the remaining portion of the decal in place with a cloth or sponge.
6. Check decal for air bubbles. If found, pierce small air pockets with a pin, then carefully smooth them out.
7. When the decal is completely smoothed out, carefully remove the top paper if present. Wipe the decal clean with a soft cloth and warm soapy water.

## General description

The Integral dx spray paver (**Figure 2**) applies emulsion volumetrically to the road surface through a system of spray bars with nozzles.

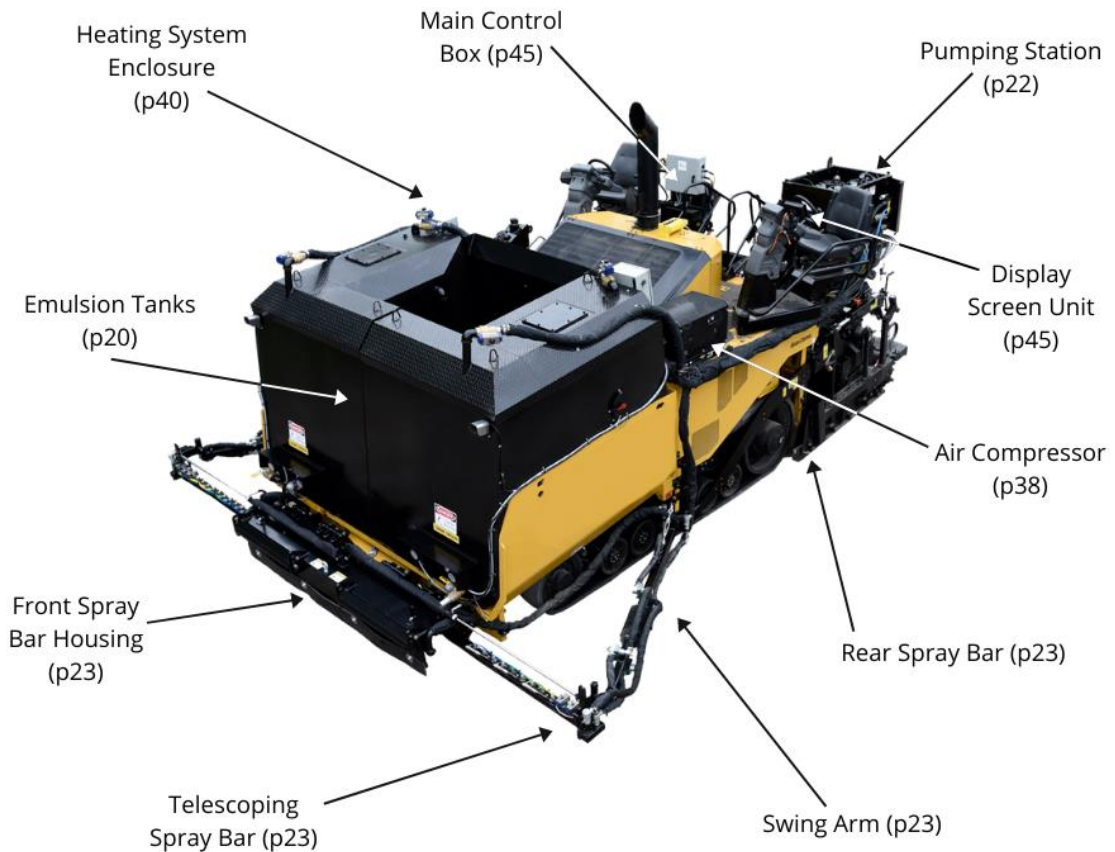

**Figure 2:** Spray paver & major components independently:

- The paver can pave with or without the spray paving system operating.
- The spray paver can operate with or without the paver operating.

The spray paver's emulsion pump(s) are capable of handling products ranging from light applications of emulsified asphalt to heavy asphalt cements heated to spraying viscosity.

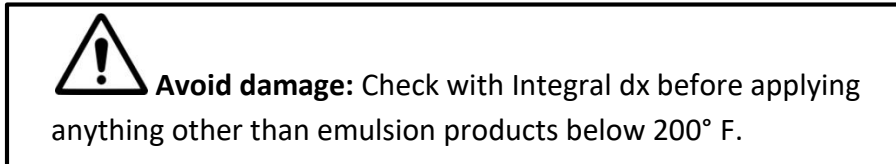

Our spray paving system has an easy-to-use display screen unit. The operator uses the display screen unit to set both application rate and spray width. Using these inputs along with vehicle speed, the display screen unit works with a control unit to automatically apply emulsion at the set application rate.

Volumetric spraying is different from using a pressure system. With volumetric spraying, each revolution of the emulsion pump achieves a specified amount of flow in gallons; flow is directly related to the pump RPM. By monitoring the pump RPM using a sensor in the hydraulic pump drive motor, the control unit knows the exact amount of flow achieved. A flow meter is not needed when using the volumetric emulsion pump(s).

The spray system is “ground oriented,” meaning it is linked to the paver speed. The spray system monitors speed using the paver speed signal; the control unit knows the exact paver speed during spraying.

As the paver speeds up or slows down, the pump also speeds up or slows down to ensure the exact application rate, measured in gallons per square yard (liters per square meter), is achieved.

The emulsion application maximum width depends upon the specific model. Spray width can be adjusted incrementally.

## General specifications

Parameter	Minimum	Maximum
Paver speed (other speeds may be achievable. Check with Integral dx.)	12.0 ft./min (3.7 m/min)	120.0 f.t/min (36.6 m/min)
Spray application volume	0.08 gal/yd <sup>2</sup> (0.33 L/m <sup>2</sup> )	0.40 gal/yd <sup>2</sup> (1.81 L/m <sup>2</sup> )
Emulsion tank temperature	35° F (2° C)	200° F (99° C)
Emulsion tank volume	NA	See Appendix 4: Emulsion tank configuration, page 151
Spray width	8 ft. (2.43 m) or 10 ft. (3.05 m) (depending upon model)	16 ft. (4.87 m) or 18 ft. (5.48 m) (depending upon model)

**Table 1:** General specifications

# Components

The spray paver is made up of three groups and four systems:

Groups:

1. Emulsion tank
2. Pump
3. Emulsion spray

Systems:

1. Hydraulic
2. Pneumatic
3. Heating
4. Control

## Emulsion tank group

The emulsion tank group includes the emulsion tank(s) and associated equipment:



**Avoid damage:** If the paver is configured with emulsion tanks mounted in the asphalt hopper, do not tilt the hopper. Attempting to tilt the hopper will damage the tanks and/or paver.

## Emulsion tank(s)

The emulsion tank is an insulated vessel that holds the hot emulsion for spraying.

One tank can be mounted on the paver deck, and/or two tanks can be mounted in the asphalt hopper (Figure 3).



**Note:** If emulsion tanks are to be removed, first drain them. Use all the lifting eyes when lifting to distribute their weight as evenly as possible.

Each tank has a dipstick and a large level indicator on the side for checking emulsion level.

Each tank has at least one drain. Drain location depends upon the tank model and is indicated by the “Tank Drain” decal. See page 101 for instructions on draining the tank.

An overflow tube on each tank is positioned to drain into the hopper.

At least one emulsion tank in the system has heating elements (see *Emulsion tank heating system*, page 46).

Top lids can be removed for filling and cleaning.

### **Emulsion tank valves**

Each emulsion tank has one pneumatically-controlled valve for drawing emulsion and another pneumatically-controlled valve for returning emulsion.

### **Tank select switch**

With multiple tanks, the operator uses a tank select switch to select a tank to use for all functions. See page 52 for more information.

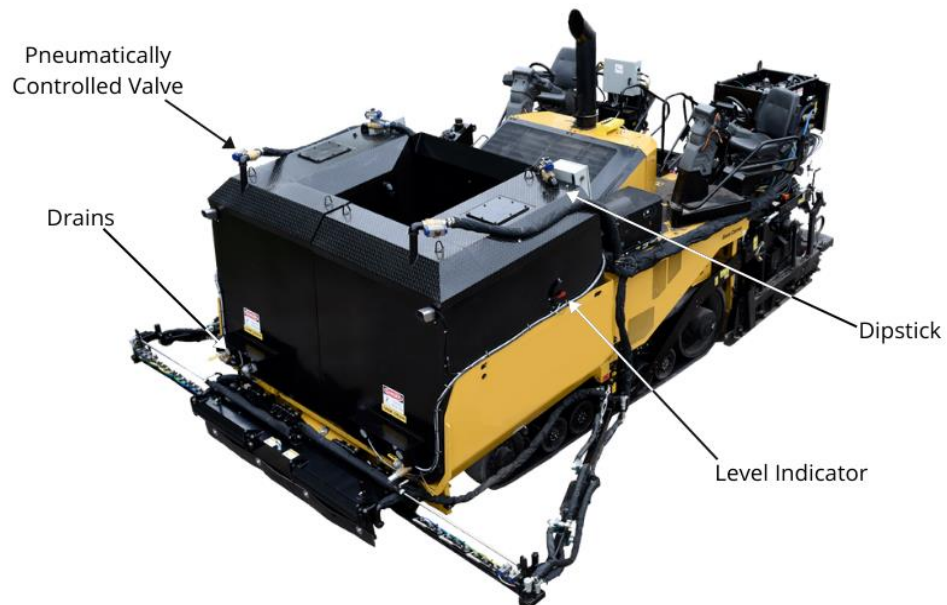
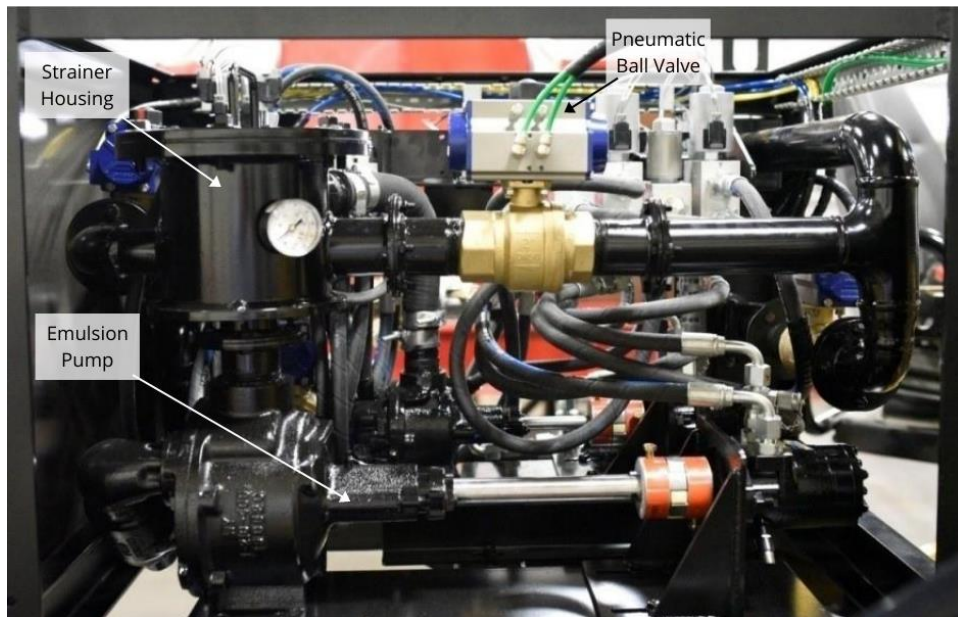

**Figure 3:** Emulsion tanks, asphalt hopper mounted

## Pump group

The pump group's function is to control the flow direction and rate of the emulsion and cleaning agent. It consists of emulsion pump(s), the strainer housing, pneumatic ball valves, all located within the pumping station.

(See Figure 4)



**Figure 4:** Emulsion pumping station (right-side view)

The pump group controls the six basic pump functions:

- Tank Load
- Tank Circulate
- Spray Bar Circulate
- Spray Auto
- Spray Bar Vacuum
- Clean Out



Valve and pump configurations for the pump functions are shown in Appendix 1: Valve and emulsion pump configurations for the pump functions, page 134.

### **Emulsion pumps**

The pump group has two pumps. The small pump is used to pump emulsion to and from the spray bars. The large pump is used for tank loading and circulation.

The pumps are driven by hydraulic motors (see page 42).

The operation of the pump is automatically determined when the operator uses the functional display screen to choose a pump function (see page 67).

### **Pneumatic ball valves**

The pneumatic ball valves are on-off valves that control emulsion flow and direction. These valves are controlled by solenoid valves (see page 44).

### **Strainer housing**

The strainer housing prevents large particles from entering the system. It receives output from both pumps and houses the strainer.

## Emulsion spray group

The emulsion spray group consists of the spray bars, spray nozzles and their valves, a spray wand attachment, and emulsion lines.

For conventional paving methods, where a dump truck is pushed along by the paver's push bar, the spray group includes an asphalt hopper extension.

### Spray bars

Spray bars on the front of the paver apply the emulsion at a minimum width equal to the distance between the inside of the tracks or tires. Spray paving width, beyond the width of the paver, is adjustable in 6-inch increments with the telescoping spray bars. The maximum width varies depending on the paver size, but 16 or 18 feet is a typical. The spray bars are configured to spray emulsion without the paver driving over the applied emulsion, utilizing the rear spray bars to fill in behind the tracks or tires.

**Front spray bar housing:** The front spray bar housing (Figure 5) contains the right and left telescoping spray bars and the center spray bar. The front spray bar housing is mounted in front of the paver hopper and replaces the paver's original push bar.



**Tip:** Cover the front spray bar housing with a thin rubber mat to help with spillage cleanup and prevent damage to the spray bar hoses, cylinders, and valves.

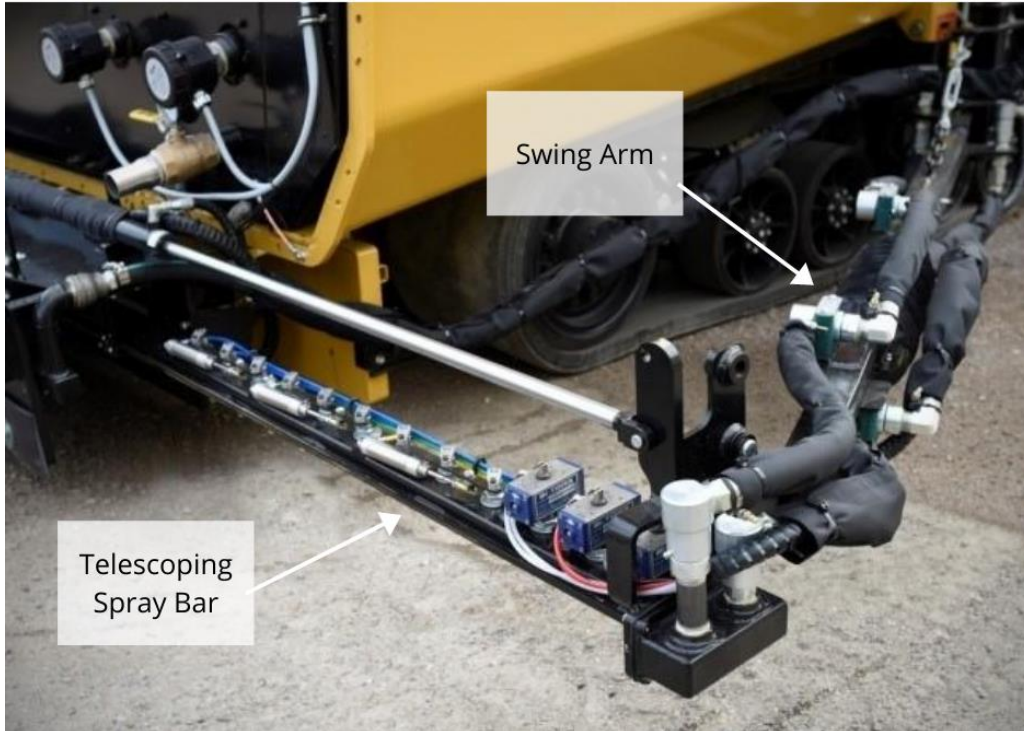

**Figure 5:** Front spray bar housing, telescoping spray bars retracted



**Avoid damage:** When the paver is used to push a dump truck, the front spray bar housing must be down and pinned in place.

**Right and left telescoping spray bars:** The right and left telescoping spray bars (Figure 6) are mounted in the front spray bar housing. Retracted, they are behind the center spray bar.



**Figure 6:** Telescoping spray bar (left) extended and swing arm

Swing arms are attached to the side of the paver and support the telescoping spray bars.

The telescoping spray bars each extend hydraulically up to 48 inches. To modify spray width, nozzles on the telescoping spray bars can be turned on or off.

- The outer spray nozzles are turned on or off individually.
- The inner nozzles are turned on or off with other nozzles on the telescoping spray bar in “gangs.”



**Avoid damage:** If the telescoping spray bars are allowed to strike an object, they can cause severe damage to property or the spray paver. Release of hot emulsion may also occur, which could injure those near the machine. Be aware of obstacles during spray paving.

**Center spray bar:** The center spray bar is mounted in the front spray bar housing. It spans the inside distance between the paver tracks or wheels. All of the center spray bar nozzles are turned on or off as a single gang.



**Figure 7:** Center spray bar

**Right and left rear spray bars:** The right and left rear spray bars (Figure 8) are mounted directly behind the tracks or wheels but in front of the auger. Each rear spray bar spans the width of the paver track or wheel. The nozzles on each rear spray bar are turned on or off as a single gang.

To prevent asphalt from the auger interrupting the spray, the rear spray bars are each protected by a shield on the back and side.

A heat strip on each of the rear spray bars turns on automatically when Spray Bar Circulate is selected.



**Figure 8:** Rear spray bar

### Spray nozzles

Each spray bar has nozzles spaced every 6 inches (4 in. on older units). The nozzles spray emulsion in a flat-fan pattern.

Spray nozzles have flow capacity ratings (in gal/min) that vary with pressure.

**Nozzle selection:** In order to obtain a uniform spray pattern and efficiently apply the asphalt emulsion, use spray nozzles with the proper flow range for the job application rate.



**Avoid damage:** Do not tighten nozzles more than firm finger tight followed by a slight wrench rotation.

- If spray nozzle flow rate is too low, the spray pattern will not be uniform, and streaking may occur. However, to reduce clogging,

use the largest spray nozzle that provides a satisfactory pattern. Paving at faster vehicle speeds increases the flow rate, allowing for a larger nozzle.

- If spray nozzle flow rate is too high, the spray pattern will include unwanted mist, and nozzle clogging will be more likely. Unnecessary overspray (loss of product) may also occur to the atmosphere and coat passing traffic.

Follow the procedure below to determine the required spray nozzle.

1. Determine the application rate in gal/yd<sup>2</sup> or L/m<sup>2</sup> to be used for the job. This will be specified by the job requirements.
2. Determine the vehicle speed that will be used for the job in ft/min or m/min.
3. Find the intersect of vehicle speed and application rate to identify the flow per nozzle. Use **Table 2** for 4 in. nozzle spacing or **Table 4** for 6 in. nozzle spacing.
4. Determine the nozzle part number using **Table 3** for 4 in. spacing or **Table 5** for 6 in. spacing



**Note:** An experienced operator can see if the spray pattern is acceptable, but if the pattern is not acceptable, selecting the proper nozzle may require some trial and error. This is because the viscosity of the emulsion, which is affected by temperature, greatly impacts the flow rate through a nozzle. Be prepared to compromise. If in doubt, choose lower speeds or a higher application rate.

Vehicle Speed	(Ft/Min)	5.000	10.000	15.000	20.000	25.000	30.000	35.000	40.000	45.000	50.000	55.000	60.000	65.000
	(Meter/Min)	1.524	3.048	4.572	6.096	7.620	9.144	10.668	12.192	13.716	15.240	16.764	18.288	19.812
Application Rate		Asphalt Flow Per Nozzle (GPM)												
(Gal/Yd <sup>2</sup> )	(L/Meter <sup>2</sup> )													
0.05	0.226	0.009	0.019	0.028	0.037	0.046	0.056	0.065	0.074	0.083	0.093	0.102	0.111	0.120
0.10	0.453	0.019	0.037	0.056	0.074	0.093	0.111	0.130	0.148	0.167	0.185	0.204	0.222	0.241
0.15	0.679	0.028	0.056	0.083	0.111	0.139	0.167	0.194	0.222	0.250	0.278	0.306	0.333	0.361
0.20	0.905	0.037	0.074	0.111	0.148	0.185	0.222	0.259	0.296	0.333	0.370	0.407	0.444	0.481
0.25	1.132	0.046	0.093	0.139	0.185	0.231	0.278	0.324	0.370	0.417	0.463	0.509	0.556	0.602
0.30	1.358	0.056	0.111	0.167	0.222	0.278	0.333	0.389	0.444	0.500	0.556	0.611	0.667	0.722
0.35	1.585	0.065	0.130	0.194	0.259	0.324	0.389	0.454	0.519	0.583	0.648	0.713	0.778	0.843
0.40	1.811	0.074	0.148	0.222	0.296	0.370	0.444	0.519	0.593	0.667	0.741	0.815	0.889	0.963
The cells highlighted in red will produce a stream rather than a fan spray pattern. Increase the paving speed to resolve this issue.														
The cells highlighted in orange will produce a good spray pattern, but excessive misting and loss of product. Decrease the paving speed to resolve this issue.														

**Table 2:** Nozzle flow – 4 in. spacing

GPM Per Nozzle Low to High		Part Number	Capacity Size
0.10	0.20	IDX10056-04	04
0.15	0.30	IDX10056-05	05
0.15	0.35	IDX10056-06	06
0.20	0.40	IDX10056-07	07
0.20	0.40	IDX10056-08	08
0.20	0.40	IDX10056-09	09
Although capacity size 07, 08, and 09 spray nozzles have the same suggested operating flow range per nozzle, improvements in spray pattern will be gained by using lower capacity sizes at the lower end of the operating range, and also by using higher capacity sizes at the higher end of the operating range.			

**Table 3:** Nozzle selection – 4 in. spacing



Vehicle Speed	(Ft/Min)	5.000	10.000	15.000	20.000	25.000	30.000	35.000	40.000	45.000	50.000	55.000	60.000	65.000
	(Meter/Min)	1.524	3.048	4.572	6.096	7.620	9.144	10.668	12.192	13.716	15.240	16.764	18.288	19.812
<b>Application Rate</b>		<b>Asphalt Flow Per Nozzle (GPM)</b>												
(Gal/Yd2)	(L/Meter2)													
0.05	0.226	0.014	0.028	0.042	0.056	0.069	0.083	0.097	0.111	0.125	0.139	0.153	0.167	0.181
0.10	0.453	0.028	0.056	0.083	0.111	0.139	0.167	0.194	0.222	0.250	0.278	0.306	0.333	0.361
0.15	0.679	0.042	0.083	0.125	0.167	0.208	0.250	0.292	0.333	0.375	0.417	0.458	0.500	0.542
0.20	0.905	0.056	0.111	0.167	0.222	0.278	0.333	0.389	0.444	0.500	0.556	0.611	0.667	0.722
0.25	1.132	0.069	0.139	0.208	0.278	0.347	0.417	0.486	0.556	0.625	0.694	0.764	0.833	0.903
0.30	1.358	0.083	0.167	0.250	0.333	0.417	0.500	0.583	0.667	0.750	0.833	0.917	1.000	1.083
0.35	1.585	0.097	0.194	0.292	0.389	0.486	0.583	0.681	0.778	0.875	0.972	1.069	1.167	1.264
0.40	1.811	0.111	0.222	0.333	0.444	0.556	0.667	0.778	0.889	1.000	1.111	1.222	1.333	1.444
The cells highlighted in red will produce a stream rather than a fan spray pattern. Increase the paving speed to resolve this issue.														
The cells highlighted in orange will produce a good spray pattern, but excessive misting and loss of product. Decrease the paving speed to resolve this issue.														

**Table 4: Nozzle flow – 6 in. spacing**

GPM Per Nozzle Low to High		Part Number	Capacity Size
0.10	0.20	IDX23452-05	05
0.15	0.30	IDX23452-06	06
0.15	0.35	IDX23452-08	08
0.20	0.40	IDX23452-10	10
0.25	0.50	IDX23452-15	15
0.30	0.60	IDX23452-20	20
Improvements in spray pattern will be gained by using lower capacity sizes at the lower end of the operating range, and also by using higher capacity sizes at the higher end of the operating range.			

**Table 5: Nozzle selection – 6 in. spacing**

**Nozzle alignment:** To achieve an even surface coverage, turn the long axis of the nozzles at a slight angle ( $\sim 10^\circ$ ) from the horizontal axis of the spray bars (see Figure 9). This prevents interference of the spray pattern.

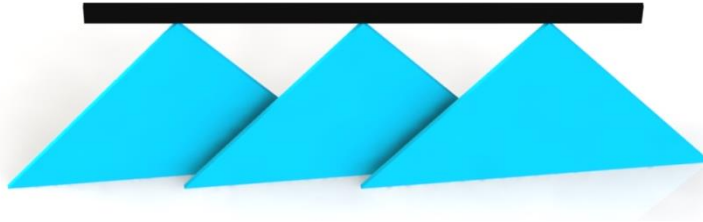

**Figure 9:** Spray pattern with 100% overlap and at a slight angle

**Nozzle height adjustment:** Set the height of the spray bars to achieve a 100 % (double) overlap; the fan reaches the center of the adjacent fan(s) (see Figure 9).



**Note:** Emulsion viscosity varies with temperature and type. Heavier emulsions require a higher nozzle height than lighter material to achieve a double overlap.

1. Adjust the height of the center and telescoping spray bars using method 1 and/or method 2.

Method 1: Add or remove spacers

- a. Support the spray bar housing using the lifting eyes.
- b. Remove the three fasteners on each of the four mounting hinges (see Figure 10).
- c. Add or remove one or more spacers (maximum four) below each mounting hinge.

- d. Adjust the swing arm height to match by removing the pin that attaches the swing arm to the telescoping spray bars and/or loosening the top/bottom nut on the adjustment bolt, which is located at the rear of the swing arms (see Figure 11).
- e. Lower the spray bar housing.
- f. Reinstall the mounting hinge fasteners.
- g. On the swing arms, reinstall the pin to the corresponding hole, and/or tighten the opposite nut on the adjustment bolt.



**Figure 10:** Front spray bar mounting hinges with spacers underneath



**Figure 11:** Swing arm height adjustment points

Method 2: Adjust the lifting tabs.

- a. Support the spray bars from the bottom.
- b. Remove the fasteners in the five front spray bar height adjustment tabs (see Figure 12).
- c. Remove the pins that attach the cylinder rods and swing arms to the ends of the telescoping spray bars (see Figure 13).
- d. Raise or lower the spray bar assembly and bolt in place.
- e. Reinstall the cylinder rods pins, swing arm pins, and the tab fasteners to the other hole.

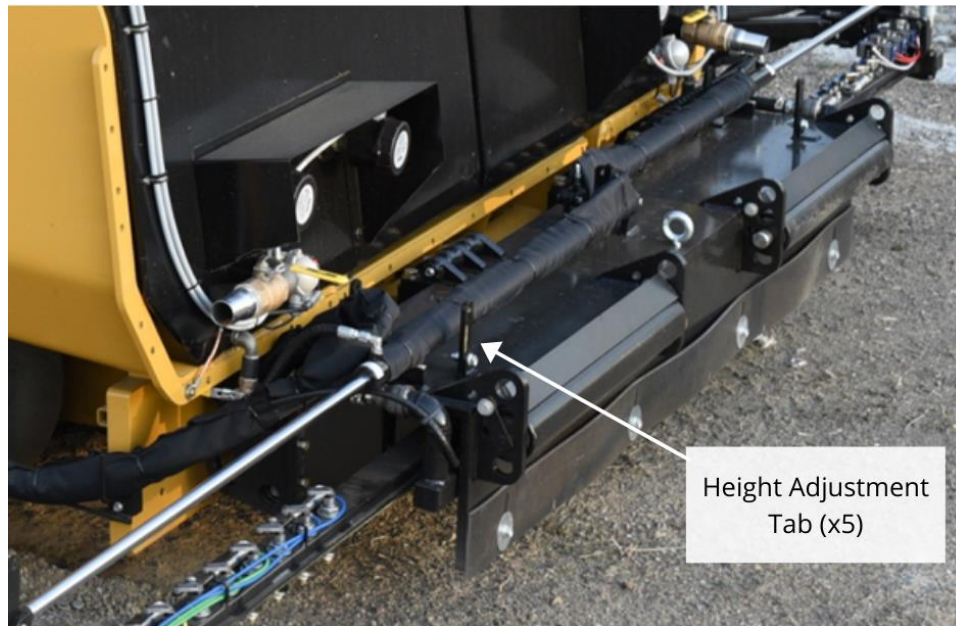

**Figure 12:** Front spray bar height adjustment tabs

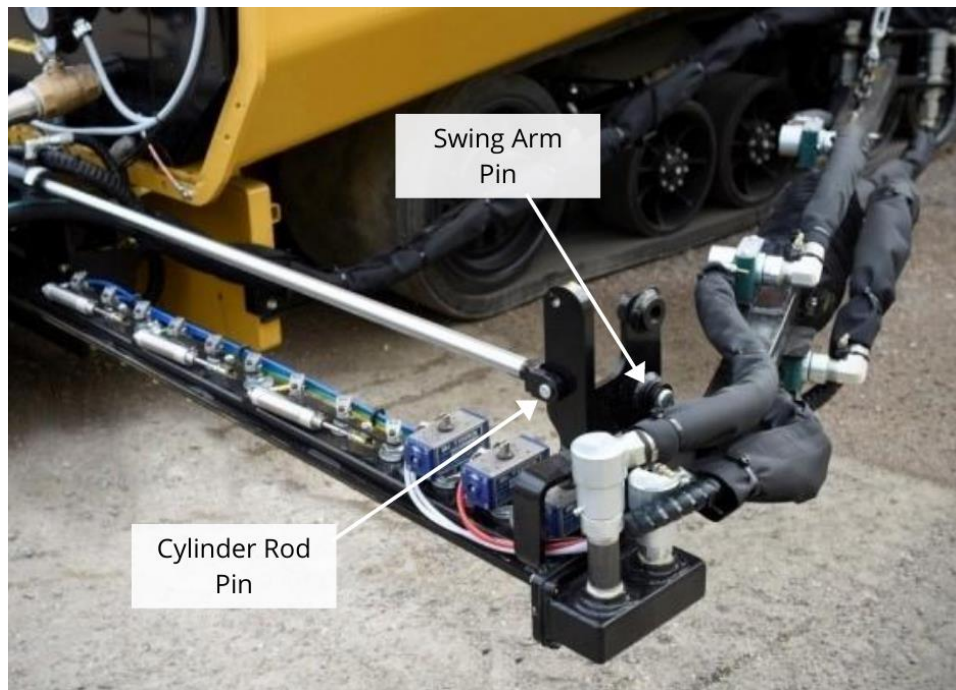

**Figure 13:** Telescoping spray bar cylinder rod pin

2. Rear spray bars adjusted by turning pipe to adjust angle between nozzles and road surface.

### **Spray nozzle valves**

Asphalt emulsion flow to spray nozzles is controlled by valves. The valves are opened or closed either individually or along with other valves in a “gang.” Individual valves are controlled with a rotary actuator while gangs are controlled with either a rotary pneumatic ball valve or pneumatic cylinder.

### **Spray wand**

The spray wand is used to apply asphalt emulsion in areas that will be paved but where it is not possible or practical to use the spray bars (e.g., when patching asphalt into driveways). An operator can use the spray wand if there is another operator on the paver.



**Tip:** While the spray wand may operate in Spray Bar Circulate, using Spray Auto with the spray master switch off will provide more pressure for a better spray pattern.

The spray wand attaches to the emulsion pumping station using a quick disconnect and has 30 feet of extension hose. The spray wand has a large capacity nozzle, which can be replaced with a smaller nozzle.

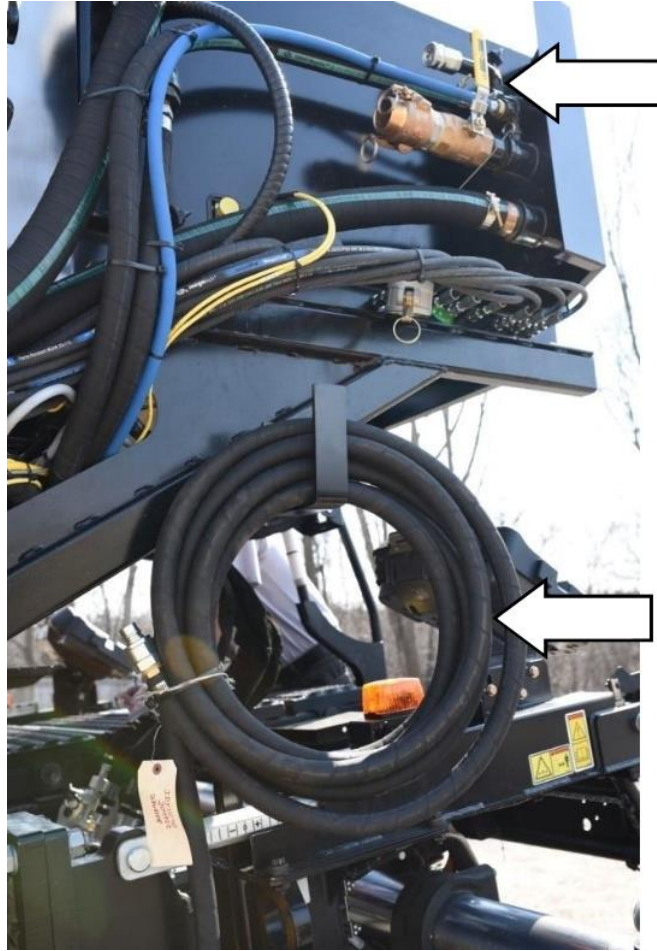

**Figure 14:** Spray wand connection and hose

### **Emulsion lines**

Emulsion lines connect the emulsion tank(s) to the pumping station and the pumping station to the spray bars.



**Warning:** Only use factory-supplied emulsion lines, emulsion line connections and hose clamps. Other hoses may rupture due to heat and cause serious injury. In most cases, a specific type of hose barb fitting is used to prevent the hose from disconnecting from the fitting. Do not use a standard worm-gear hose clamp, which will not meet requirements.

### **Asphalt hopper extensions (optional)**

For conventional paving, where a dump truck is pushed along by the paver's push bar, the spray group includes an asphalt hopper extension (see Figure 15).

The hopper extensions maintain proper interface with asphalt trucks. Since the center spray bar runs between the hopper and the rollers that push the asphalt truck, the asphalt hopper extension allows for correct depth of dumping into the paver, minimizing spillage.



**Figure 15:** Asphalt hopper extensions



## Hydraulic system

The hydraulic system is pressurized by a piston pump. The pump provides fluid power to the hydraulic motors and hydraulic cylinders. A hydraulic reservoir supplies hydraulic fluid to the system. Valves control motor and cylinder function.

### Piston pump

The piston pump (Figure 16) is dedicated to the spray paving hydraulic system. The pump is typically powered by an unused PTO located on the paver engine. The pump is a load sense pump with maximum pressure set at 2450 psi.



**Figure 16:** Hydraulic piston pump

### Hydraulic reservoir

The 25-gallon hydraulic reservoir with an integral cooler (Figure 17) supplies hydraulic oil to the pump as well as cools and filters the hydraulic oil. The reservoir has a temperature sensor that displays hydraulic oil temperature on the operators display.



**Warning:** The oil cooler fan is thermostatically controlled. It may startup at any time, even if the paver is not running. To prevent injury or damage, keep fingers and objects away from the fan.



**Figure 17:** Hydraulic reservoir

### **Hydraulic motors**

Fixed displacement hydraulic motors directly drive the large emulsion pump and the small emulsion pump.

### **Motor valves**

Direction of the emulsion pump motors are controlled by reversing valves, one for each motor. Speeds of the hydraulic motors are controlled by proportional valves, one for each motor. These valves are connected to the control system. All are located in the emulsion pumping station.

### **Hydraulic cylinders**

Hydraulic cylinders are used in the front spray bar housing to do the following:

- Extend and retract right and left telescoping spray bars, one on each side.
- Tilt the front spray bar housing.
- Lock the front spray bar housing up or down, one on each side.

## Cylinder control valves

Valves in the pumping station control the hydraulic cylinders:

- Solenoid valve for the two cylinders that extend/retract the telescoping spray bars.
- Solenoid valve and check valve for the cylinder that raises/lowers the front spray bar housing.
- Solenoid valve for the two cylinders that lock the front spray bar housing up or down.
- The solenoid valves are connected to the control system. The check valve operates from pressure within the system.

## Needle valves

Needle valves in the pumping station adjust the hydraulic flow to the cylinders.

There are three: one for each telescoping spray bar extension/retraction cylinder and one for the cylinders that tilt the front spray bar housing.



**Note:** The needle valves are set at the factory and likely will not need adjustment.

## Pneumatic system

The pneumatic system includes an electrically driven air compressor. (Figure 18) This system also includes the solenoid valves, which control the various valves.

Some models have an auxiliary connection at the compressor for a compressed air supply.

### Air compressor

The air compressor is located on the paver or screed deck. It provides compressed air to the solenoid valves and ultimately to the pneumatic valves that control many of the spray paver functions.

The air pressure is regulated by a pressure switch.

The compressor cycles between approximately 85 psi and 125 psi.

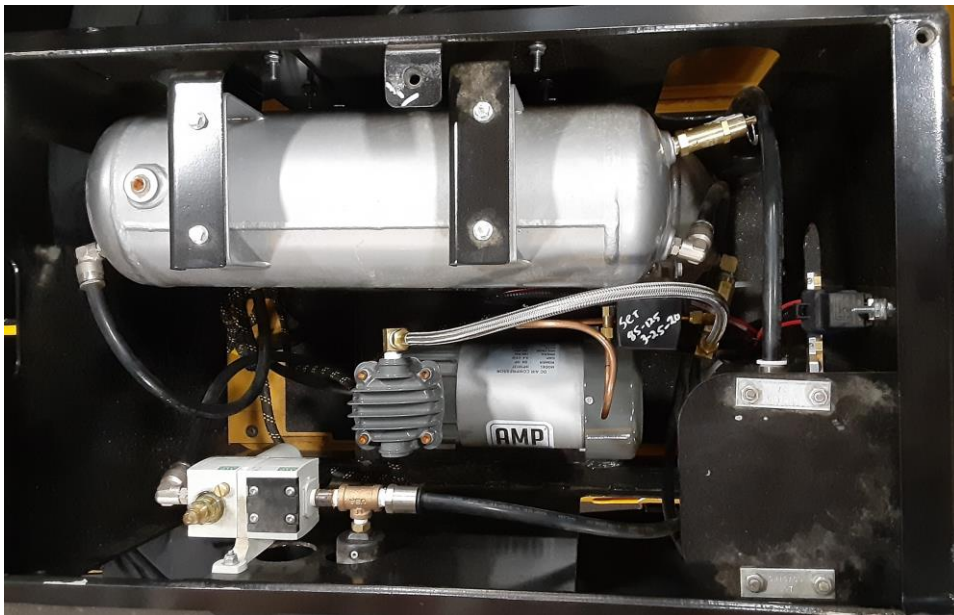

**Figure 18:** Air compressor (top view, cover off)

### Solenoid valves

The solenoid valves turn the pneumatic valves on/off based on signals from the control system. The solenoid valves are grouped in four manifolds. Color-coded air lines facilitate troubleshooting. The manifolds are mounted in four enclosures and control the following:

- Pneumatic actuators, cylinders or rotary actuators that turn on or off the spray nozzles (individuals or gangs) on the front spray bars and ball valves that turn on/off the rear spray bars.
- Emulsion tank valves (one valve on each tank for drawing emulsion and another valve on each tank for returning emulsion).
- Pneumatic ball valves in the pumping station.



**Note:** If air pressure is lost for any reason, including compressor malfunction, the pneumatic valves will no longer operate and will remain in their last position.



**Note:** If electrical signal to the valve is lost, the valve can be manually operated by turning the screw with a flat-tipped screwdriver.

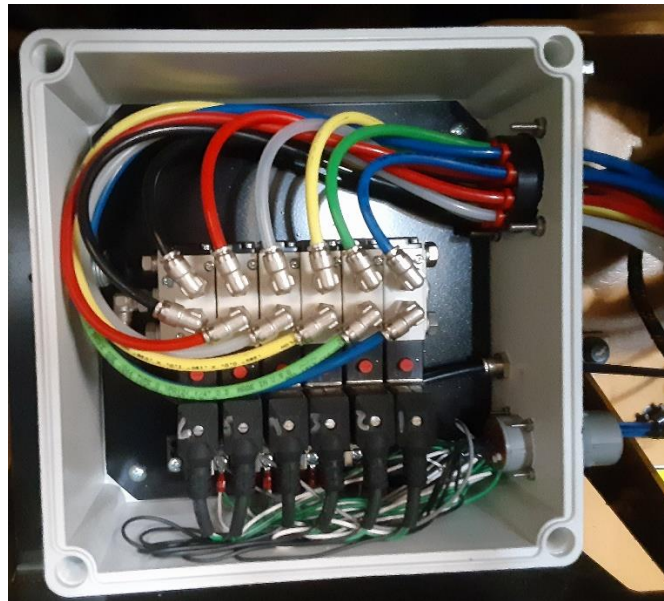

**Figure 19:** Solenoid valve manifold in its enclosure

## Emulsion tank heating system

The emulsion tank heating system consists of the heating elements, the heating system enclosure with the thermostat, the emulsion tank low level switch, the emulsion tank over-temperature switch, and the temperature gauge.

The heating system is powered either by the paver's 120 or 240-VAC generator or external power of 120 or 240 VAC.



**Note:** Breaker selection on your paver is unique and needs to be reviewed by the installer.

### Heating elements

At least one emulsion tank in the system will include heating elements. Other tanks may or may not have heating elements, depending upon the options chosen. The heating elements are controlled by a thermostat with temperature sensor (see Figure 20).



**Tip:** Keep emulsion above 165° F (typically) to prevent it from solidifying and clogging the system.

A heating element has a heating capacity of 4 kW at 240 volts or 2 kW at 120 volts. The tank can be held at 50° F to 200° F.

- Using a 500-gallon emulsion tank with two heating elements at 240 VAC, the heating system will maintain 180° F.



**Tip:** Because the heating elements are sized to maintain temperature, heating cold emulsion to spray temperature may be very slow. Therefore, the tank should be drained before overnight or prolonged storage.

- 120 VAC (external power) will only limit the temperature drop of the emulsion. For example, with a 500-gallon emulsion tank using two heating elements, if the emulsion starting temperature is 180° F at 70° F ambient, the operator can still expect a 20 to 30° F drop over 12 hours. Ambient temperatures below 70° F can hasten cooling and increase the time required for reheat.



**Tip:** If ambient temperature is expected to be well below 70° F, and 220 VAC external power is not available, remove emulsion from the tank for the overnight. Note that clean out or release agent rinse is advised when emulsion is removed.



**Warning:** Never plug the emulsion tank into external power unless the paver is in a well-ventilated, outside location and there is enough emulsion to cover the heating elements.



**Warning:** Never leave the emulsion tank plugged into external power overnight unless the paver unit is in a secured location. The plugged-in unit must not be accessible by untrained people. Provide security, or drain the emulsion tank and do not plug in overnight.



**Figure 20:** Tank heating elements and thermostat temperature sensor

### Heating system enclosure

A heating system enclosure (Figure 21) is mounted on each tank. Inside is the thermostat for regulating the tank heating temperature, as required by the type of emulsion being used.



**Warning:** Never let the emulsion get above 200° F. Boiling will occur if the temperature is too high and cause potential burn injuries. Also, the water base will evaporate, changing the properties of the emulsion.

LEDs on the enclosure light up when the heating elements are on (see Figure 21).



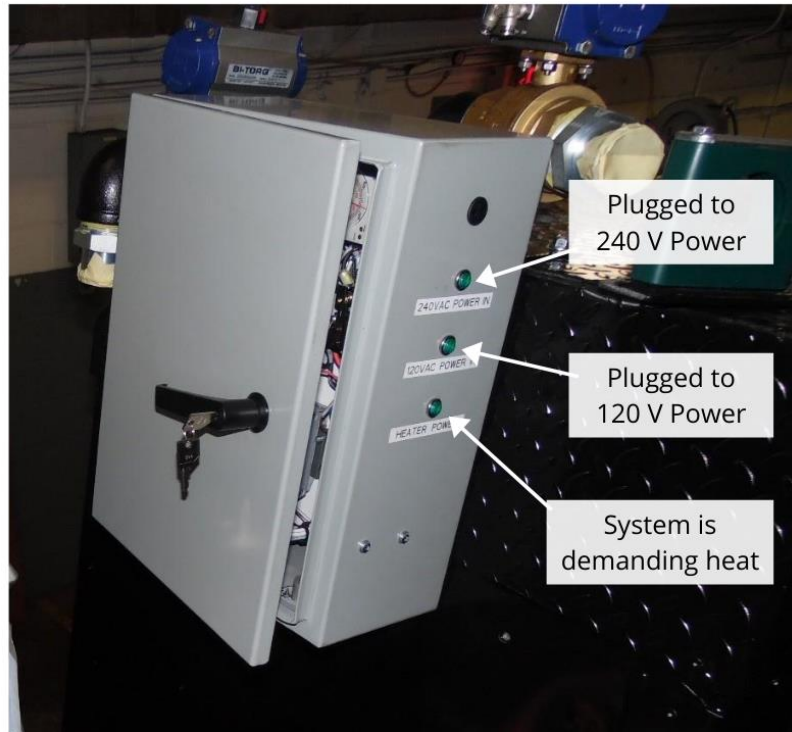
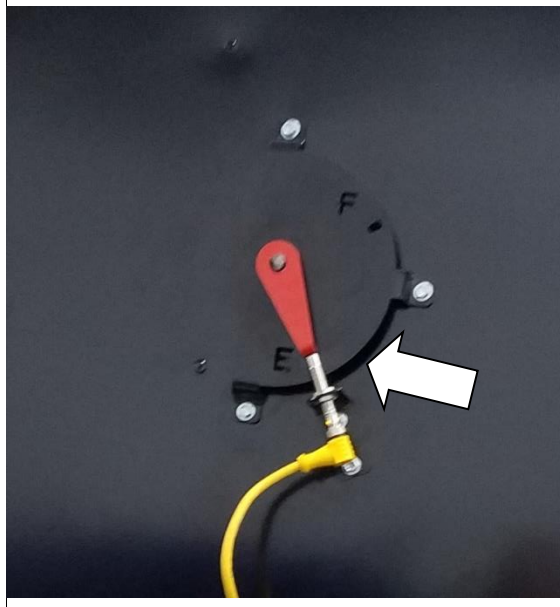

**Figure 21:** Heating system enclosure and LED designation

### Emulsion tank low-level switch

 **Avoid Damage:** Never operate the tank heating elements unless they are fully submerged.

The emulsion tank low-level switch (Figure 22) is attached to the tank level indicator. It shuts off the heating elements when the emulsion in the tank is low enough that the heating elements will be exposed.

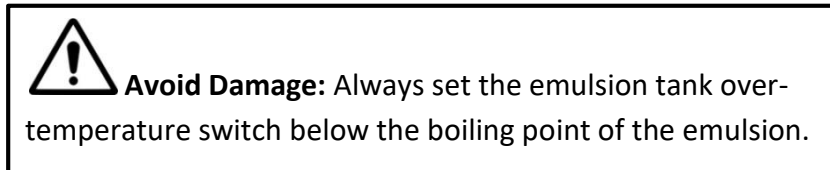

**Figure 22:** Emulsion tank low-level switch

### **Emulsion tank over-temperature switch**

The emulsion tank over-temperature switch (Figure 23) is attached to the tank next to the thermostat temperature sensor. It is a backup that turns off tank heat in case of thermostat failure.

To adjust the switch, loosen the ring, turn the dial to the desired temperature setting, and tighten the ring. Note: on newer machines the switch is not adjustable.



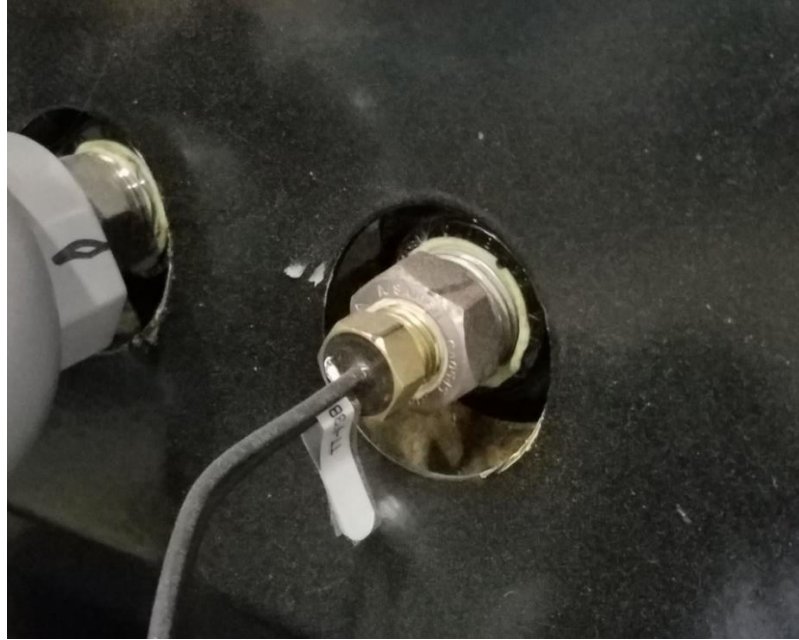

**Figure 23:** Emulsion tank over-temperature switch.

### **Temperature gauge**

The temperature gauge is mounted near the heating elements.

### **Control system**

The spray paver's control system operates pump functions and maintains the emulsion application rate as set by the operator. The control system is powered by the paver's 24 VDC electrical circuit.

### **Emulsion flow rate determination**

The control system sets the emulsion flow rate by regulating the speed of the emulsion pumps. It does this by regulating the hydraulic flow rate delivered to the pump hydraulic drive motors.

The following inputs are used by the control system to set emulsion flow rate:

- Application rate (in gal/yd<sup>2</sup> or L/m<sup>2</sup>) – Set by the operator
- Spray bar width – Calculated from operator's spray nozzle selection
- Vehicle speed – Determined by input from the paver
- Emulsion pump speed – Measured by the speed sensor in the hydraulic motors that drive the small and large emulsion pumps

If vehicle speed is increased or decreased, pump speed will increase or decrease to maintain the desired application rate.

## **Components**

The control system consists of these major components:

- Display screen unit
- Pendant control
- Control unit
- Fuse panel
- Signal splitter
- Emulsion pump speed pickups
- Tank selector switch

### **Display screen unit**

Using the 7-inch (178 mm) display screen unit (Figure 24), the operator selects variables and controls the functions of the spray paver.

The display screen unit is located near the operator control console, but its location varies with the configuration.



**Figure 24:** Display screen unit

The following are some of the tasks an operator performs through the display screen unit (see page 60 for specific operation):

- Operate pump functions
- Extend & retract the left and right telescoping spray bars, tilt the front spray bar housing, lock the front spray bar housing
- View and adjust spray width through nozzle selection
- See if the master spray switch (on the pendant control) is on or off
- Display machine totals and job totals, and reset job totals.
- View alarms that alert operators of dangers or system issues
- Display optional video camera(s) output (up to two video cameras may be installed)
- View speeds of small and large pumps
- View emulsion flow rate
- Enter small and large emulsion pump calibration factors
- Change vehicle speed calibration factors
- Select the language used by the display screen unit
- Change measurement units
- View sensor feedback of system parameters
- Run Troubleshooting Sequence

## Pendant control

The pendant control is a hand control for the spray paver (Figure-25). It is used by the seated operator, an operator riding on the screed, or an operator walking alongside the spray paver. It has the following controls:

- The red mushroom (on/off) button serves as the power switch for turning on/off the spray paving system and also is the emergency stop button. Pull it up to power on. Press it down to disable power.

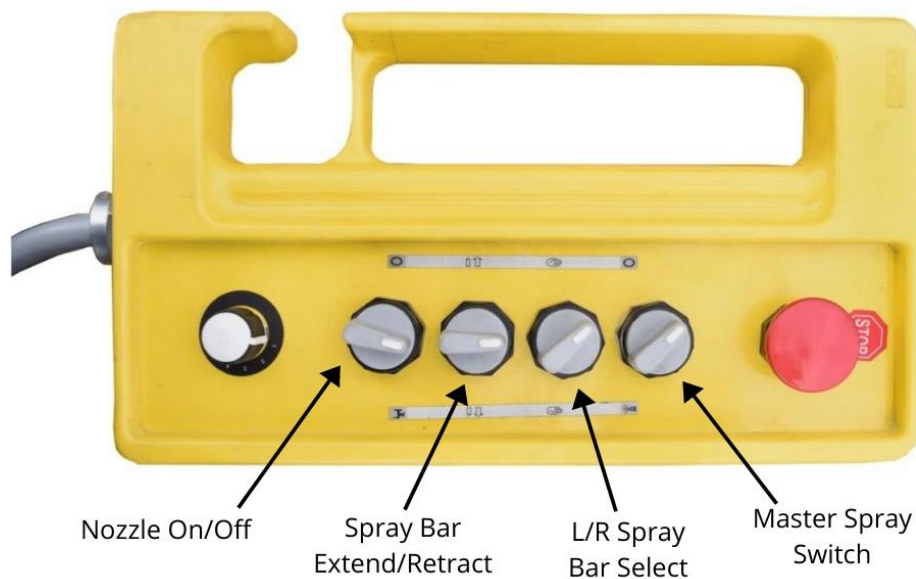

**Figure 25:** Pendant control

- The master spray switch is a two-position switch and will open or close the spray nozzle valves selected on the display screen unit. See “Using the display screen unit” on page 63 for more detail.
  - “Off” must be selected before starting the pump in Spray Auto. For best results, it should be selected before opening the nozzles in Spray Bar Vacuum and Spray Bar Clean Out.
  - “On” turns selected spray nozzles on.



**Note:** In certain pump functions the master spray switch is disabled. For example, an operator should not be operating the spray nozzles while running the Tank Load function, so the master spray switch is disabled for this pump function. See “Using the display screen unit” on page 63 for more detail.

- Left/right spray bar select is a two-position switch used to select either the right or the left telescoping spray bars.
- The spray bar hydraulic extend and retract switch extends or retracts the telescoping spray bar selected.
- The rotating nozzle selection switch is a five-position switch (six-position on machines with 4” nozzle spacing) that selects a nozzle or gang of nozzles for turning on or off on the telescoping spray bar selected. The settings are from the inner most (1) to the outermost (6).
- The nozzle on/off buttons toggle on or off the nozzle or gang of nozzles currently selected on the rotating nozzle selection switch. The HMI shows that gang or nozzle selected or deselected the same as if the change were made from the HMI.

## Control unit

The control unit is an electronic processor that is connected to various machine components as well as the operator display.

Inputs are received (paver speed, pump speed, pendant control master spray switch, air compressor pressure) and outputs are delivered to machine components (valves, rear spray bar heaters) as programmed in the control unit code.

The control unit is housed in main control box (



Figure 26).

**Figure 26:** Main control box



### **Fuse panel**

The fuse panel is housed in the main control box.

### **Signal splitter**

The signal splitter receives the vehicle speed signal as an input and it outputs two speed signals. One goes to the paver as usual and the other speed signal is delivered to the control unit. The signal splitter is housed in the main control box.

### **Emulsion pump speed pickups**

The emulsion pump speed pickups are on the pump hydraulic motors. They send signals that are used to calculate emulsion flow to the control unit.

### **Tank select switch**

With models that have more than one emulsion tank, a tank select switch (**Figure 27**) is mounted on the side of the main control box. Use the switch to select which tank will be used for all functions



**Figure 27:** Tank select switch

# Installation

## System delivery and inspection

Before unloading, check the spray paver components for any damage that may have occurred during shipment. Note any damage and immediately contact the carrier to make a damage or shortage claim. Also contact Integral dx.

## Machine setup

Perform the small asphalt pump calibration at the typical paver speed and typical application rate. (See page 113.)

Adjust the height and angle of the spray nozzles (see page 33).

# Operation

## Pre-operating precautions



**Warning:** Always be sure all controls and gauges are operating properly before starting a job. Do not operate the machine if any of the warning buzzers/lights are ON. If any malfunctions are found prior to or during operation, shut down the machine and report the problem to a supervisor.



**Warning:** Keep all hydraulic lines, fittings and couplers tight and free of leaks. Leaking fittings are a fire hazard.



**Warning:** The operator is responsible for the work area. Clear the area of people before starting or operating the unit. Death or serious injury can occur to bystanders if sprayed with hot emulsion.



**Warning:** Clean reflectors and lights before transporting to help avoid collisions with other traffic.



**Danger:** Walk around the machine and be sure to warn all personnel in the area before starting the machine. Be sure the area is clear before starting. Death or serious injury can occur to bystanders if sprayed with hot emulsion.

## Operating precautions



**Warning:** Know and use the hand signals required for each job and know who has the responsibility for signaling.



**Danger:** Keep hands, feet, hair, and clothing away from moving parts. Death or serious injury can occur from entanglement in moving parts.



**Danger:** Watch for bystanders and never allow anyone to reach into the machine while it is operating. Note: some tank configurations will limit operator visibility.



**Danger:** Do not go under the vehicle when the engine is running. Death or serious injury can occur if one becomes crushed by or entangled in moving parts.



**Warning:** Be sure to reinstall safety devices, guards or shields after adjusting and/or servicing the machine. Death or serious injury can occur from entanglement in moving parts.

## Fire and explosion precautions



**Warning:** Keep machine and emulsion material away from sparks, incandescent material and open flames. Fumes may be flammable and can explode.



**Warning:** Do not operate where flammable gas may be present.



**Warning:** Do not smoke around the machine. Fuel, emulsion, and the fumes from both can explode when exposed to flame or heat from smoking or other sources.



**Warning:** When working around asphalt emulsion, first you must immediately be aware of the danger of steam explosions. Second, you must consider you are near a HOT material that can burn skin, eyes, face, & hands. Always be aware of the position of hoses you are handling relative to YOURSELF AND THOSE AROUND YOU, and the hot-hot material inside.

## Hydraulic system precautions



**Danger:** Before applying pressure to the hydraulic system, make sure all lines, fittings, and couplers are tight and in good repair.



**Danger:** Make sure that all components are in good working condition and are clean. Replace any worn, cut, abraded, flattened or crushed hoses, and metal lines.





**Danger:** Wear proper hand and eye protection when searching for hydraulic leaks. Pressurized hydraulic fluid or oil has sufficient force to penetrate the skin. Serious infection or toxic reaction can develop from hydraulic fluid piercing the skin. If injured by high pressure stream of hydraulic fluid, seek medical attention immediately. Use a piece of wood or cardboard as a backstop instead of hands to isolate and identify leaks. Do not use your hands. Relieve pressure on the system before making repairs or disconnecting lines, hoses, or valves.

# Using the display screen unit

## Start screen

The start screen (Figure 28) will come up initially when turning on the red mushroom (on/off) button on the pendant control.

 **Note:** Settings last used when powered down are retained and activated during startup.

 **Note:** Keys may change function depending upon the screen. Figure 28 shows the key naming (1L - 5L and 1R - 5R) that will be used in this manual.

 **Note:** Active keys on the display are illuminated. Keys that are not enabled are dimmed.



**Figure 28:** Start screen showing key naming

## Display navigation

The Sprayer Selection screen (**Figure 29**) is the first to appear.

Use keys [1L] and [2L] to move forward and backward through the display screens:

<>Sprayer Selection<>Pump Function<>Totals<>Camera1<>Camera2<>Password

**Note:** Keys [1L] and [2L] are dedicated; arrows are always present, but are disabled when certain pump functions are active.

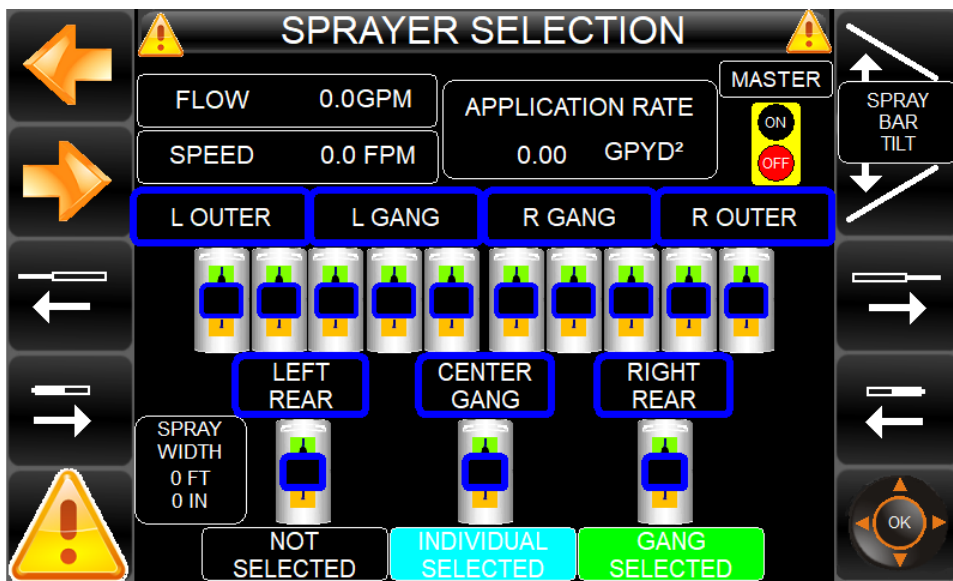

**Figure 29:** Display navigation keys on Sprayer Selection screen



## Sprayer selection screen

Use the Sprayer Selection screen (Figure 30) to select/deselect the spray nozzles or gangs of nozzles that will spray.

Also use this screen to extend or retract the telescoping spray bars and to tilt the front spray bar housing up and down.

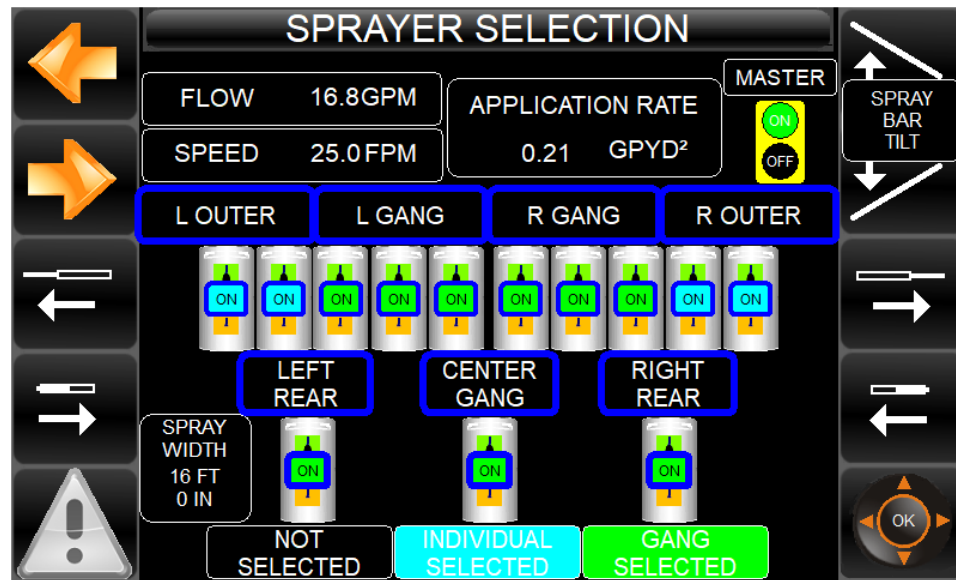

**Figure 30:** Sprayer Selection screen: all switches selected, pump on in Auto Spray, and master spray switch on

The upper row of switches is for the left and right telescoping spray bars. Each of the telescoping spray bars has a group of switches that control an individual nozzle (the outer nozzles) and a group of switches that control a “gang” of nozzles (the inner nozzles).

The bottom row of switches is for the front center section and the left and right rear spray bar sections. All of these switches control a “gang” of nozzles.

As noted on the bottom of the screen, the color of the switch also indicates whether it is for an individual nozzle (blue) or a gang of nozzles (green).

Flow, speed and application rates are readouts only. Change application rate by selecting **Pump Function>Spray Auto**.

### Selecting operation of spray nozzle (or group of nozzles)

1. Use the multi-navigation key [5R] to move through the range of nozzle valve switches. The current selection is highlighted with a dark blue box.



**Note:** With the telescoping spray bars, you can select a complete spray bar by selecting [L outer and L gang] or [R outer and R gang], or you can select an individual switch.

2. Press the center of the multi-navigation key to select or deselect an individual switch or an entire spray bar. A switch is blackened when it is deselected.



**Tip:** To select combinations of spray bar sections, push the up arrow on the multi-navigation key. The selections are highlighted with a dark blue box.



**Note:** Master (the master spray switch) status on/off is also indicated and will apply to all the selected switches. However, the only way to turn the master spray switch on/off is with the pendant control.

Figure 30 shows some switches selected, all of which are turned on because 1) the master spray switch is on, and 2) the pump in Spray Auto is on (see the Pump Function section below).

Figure 31 shows all switches selected, but the master switch is off.

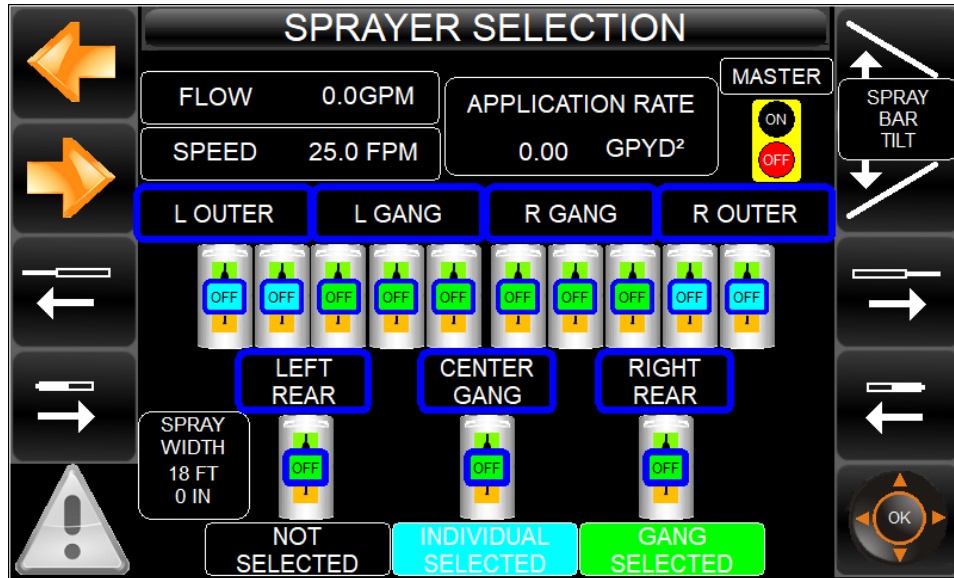

**Figure 31:** Sprayer Selection screen: all switches selected, master spray switch off

### Extending or retracting spray bars

- Press and hold button [3L] for left telescoping spray bar extension and button [4L] for left telescoping spray bar retraction.
- Press and hold button [3R] for right telescoping spray bar extension and button [4R] for right telescoping spray bar retraction.

**Note:** The spray width indicated is the overall width and depends upon the switches selected on the telescoping spray bars.

### Tilting the front spray bar housing

From Totals screen (page 72), unlock the front spray bar housing before tilting. Lock it back in place after tilting from the same screen.

- Press and hold key [2R] to tilt the front spray bar housing down for spraying.
- Press and hold key [1R] to tilt the spray bar assembly up after spraying is complete.



**Tip:** To automatically unlock and then lock the spray bar housing after tilting, turn on the tilt lock on the Totals screen (see page 72), and push the tilt button for a total of at least 3 seconds.

## Pump function screen

Use the Pump Function screen (Figure 32) to select a pump function, start the pump, and set the pump rate (application rate with Spray Auto)

Also use this screen to tilt the front spray bar housing up and down.



**Note:** Selecting Spray Bar Vacuum brings up a second screen to set further parameters and start the pump. See page 71.

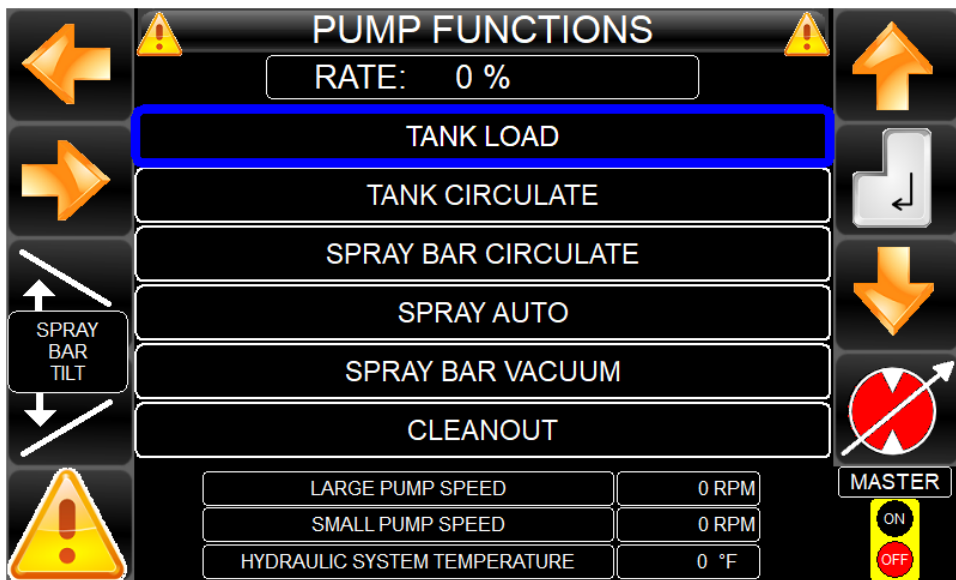

**Figure 32:** Pump function screen

The flow rate (as a percentage) for the selected function is listed at the top of the screen, and the emulsion pump speeds are listed at the bottom of the screen. Flow does not go to zero when percentage is at zero.

### Activating a pump function

1. Use the **Value scrolling arrow keys** [1R] and [3R] to select a pump function. The current selection is highlighted.
2. Press the **Enter** key [2R]. The pump function selected and rate box will turn red.
3. Press the **Pump on/off** key [4R]. “Warning. Pump will start!” (Figure 33) will appear.



**Figure 33:** Pump will start warning screen

4. Ensure that people and obstacles are clear of moving parts.
5. Select the **Yes** key [1R] to start the pump. The selected pump function, the pump symbol and the rate box will turn green.

**Note:** Starting Spray Auto is ultimately done using the spray master switch on the pendant control to open the nozzles. If the spray master switch on the pendant control is on, the operator cannot turn on the pumps, and the display will advise “Turn off the master switch!”

 **Note:** The “RATE” box will turn green when pump is commanded on. The pump symbol turns green when the pump is in operation and the controller receives feedback from the pump speed sensor.

### Setting the flow rate

1. Activate the pump function as outlined above.
2. Press the value scrolling keys [1R] and [3R] to set the flow rate. The rate can be changed while the pump is running and will immediately adjust.

 **Note:** Spray Bar Vacuum has a fixed rate.

 **Note:** In Spray Auto, rate is the application rate and is in gal/yd<sup>2</sup> or L/m<sup>2</sup>. With all other pump functions, the rate is a percentage of full pump capability.

### Tilting the front spray bar housing

- Press and hold key [3L] to tilt the front spray bar housing down for spraying.
- Press and hold key [4L] to tilt the spray bar assembly up after spraying is complete.

 **Note:** From Totals screen (page 72), unlock the front spray bar housing before tilting. Lock it back in place after tilting from the same screen.

## Spray bar vacuum screen

Use the Spray Bar Vacuum screen (Figure 34) to set the spray bar to be vacuumed and initiate the pump.

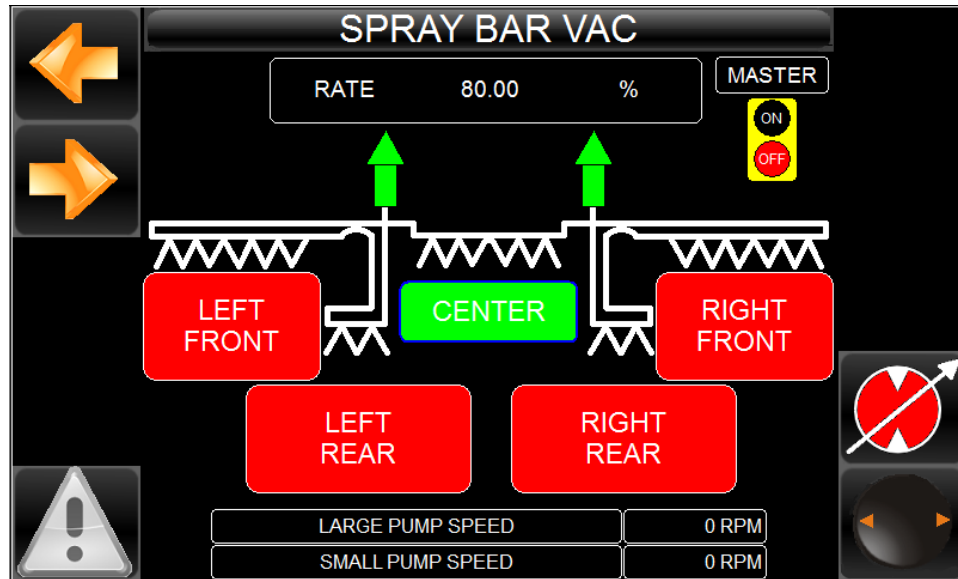



Figure 34: Spray bar vacuum screen

Vacuuming a section of the spray bar

1. Use the **multi-navigation key** [5R] to select spray bars: left and right front, center, or left and right rear. They will highlight in green.
2. Press the **Pump** key [4R] to activate the Spray Bar Vacuum pump function. "Warning pump will start!" will appear.
3. Press the **Yes** key [1R] to start the pump. The rate will turn green.

 **Note:** The rate is fixed.

 **Note:** If the spray master switch on the pendant control is on, the display will advise "Turn off the master switch!"

## Totals screen

Use the Totals screen (Figure 35) to see information about the work totals performed by the spray paver.

Also use this screen to lock or unlock the front spray bar housing.

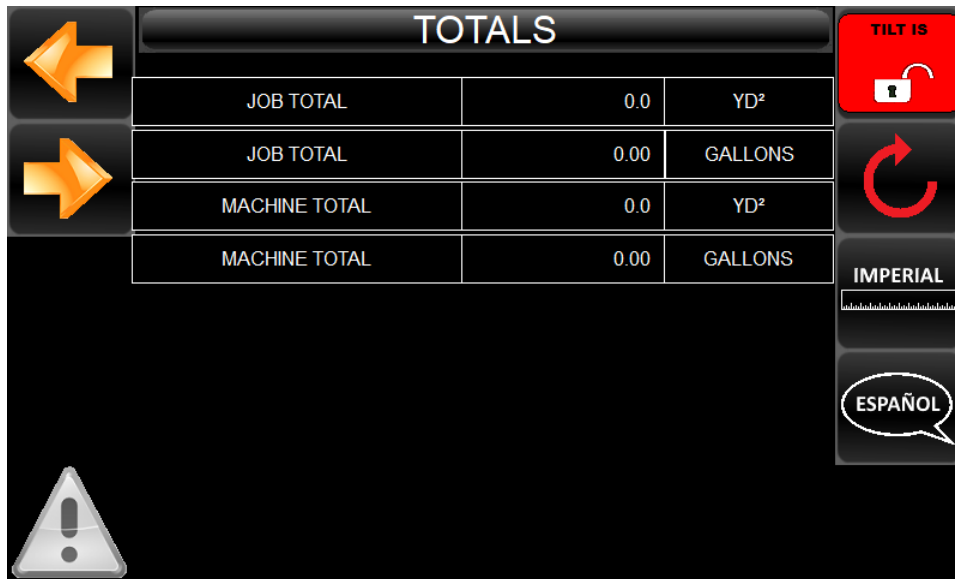

**Figure 35:** Spray totals screen

Job totals shows the amount of work done since the last reset. To reset the Job totals, press and hold the Reset key [2R] until the values for the square yards and gallons are returned to zeros.

Machine totals shows the amount of work performed in the life of the spray paver. It can only be reset by the factory.

Press the Tilt Lock key [1R] to lock and unlock the front spray bar housing after it is tilted up or down.



## Camera screens (1 and 2)

The camera screens (Figure 36), show the output of optional cameras. Use keys [1R] and [2R] to move between screens.

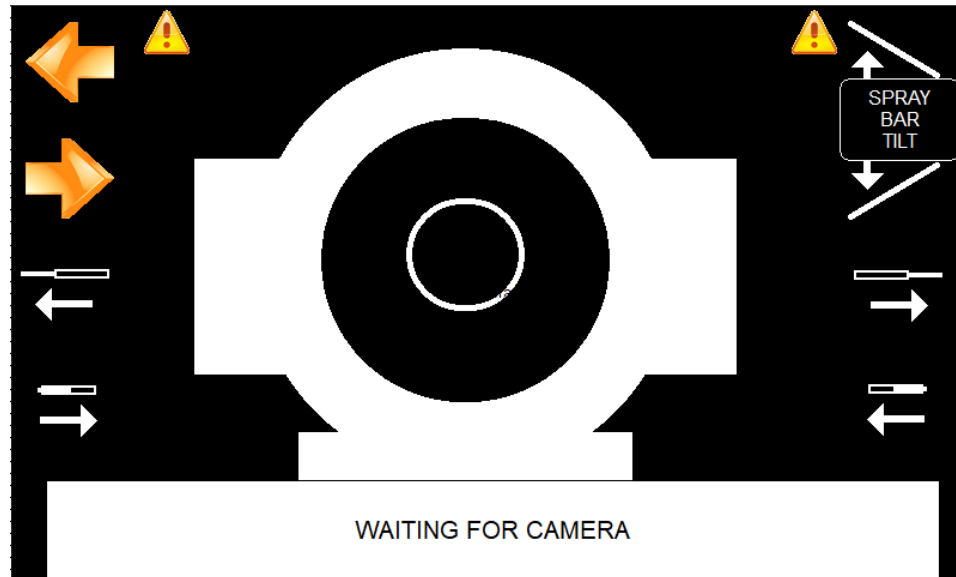
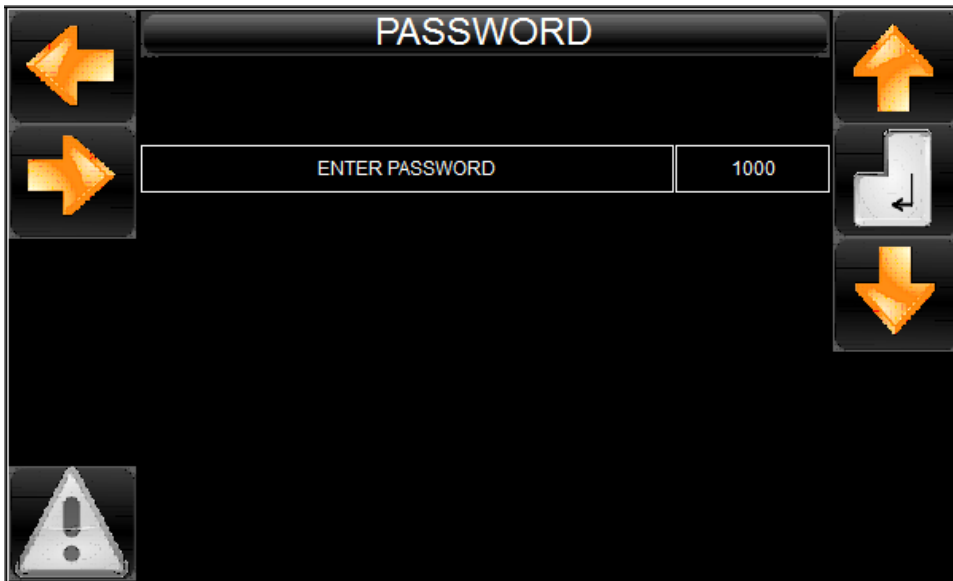

**Figure 36:** Camera screen

The spray bar can be tilted from either camera screen using buttons [1R] and [2R]. The left and right telescoping spray bars can be extended and retracted using buttons [3L], [4L], [3R], and [4R].

## Password screen

The password screen (Figure 37) is the way to access the Service Screen. The four-digit password can be changed within the Service Screen (below).



**Figure 37:** Password screen

To enter the password number, use the up and down arrow keys [1R] and [3R] to scroll through numbers. When you find your number, let up on the arrow, and the Service Screen will appear. When delivered from the factory, or if new software is installed, the password is set to 1234.





## Service screen

Use the service screen (Figure 38) to set values and adjust settings for various operations of the spray paver as follows:

1. Move through the service options using the value scrolling arrow keys [1R] and [3R].
2. Press the **Enter** key [2R], to activate the selected option.

 **Note:** See page 113 for determining the small pump calibration factor. There is not a procedure for large pump calibration.

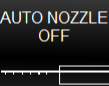
3. Use the value scrolling arrow keys [1R] and [3R] to reach the desired setting.
4. Press the **Enter** key [2R] to save the selected setting.

	SERVICE			
PAGE BACK		SMALL PUMP CALIBRATION FACTOR	1000	SCROLL/VALUE UP
PAGE AHEAD		LARGE PUMP CALIBRATION FACTOR	1000	SELECT/ENTER VALUE
AUTO NOZZLE ON/OFF	AUTO NOZZLE OFF 	PULSES PER FOOT	831.0	SCROLL/VALUE DOWN
TROUBLESHOOT SEQUENCE		PASSWORD	1234	SYSTEM DATA
ALARMS		CAMERA 1	ON	NOT USED
		CAMERA 2	ON	
		SIMULATED VEHICLE SPEED	30.0 ft/min	
		START UP COVERAGE DISTANCE	10.0 FT	
		SPRAYBAR EXTENSIONS	OFF	

**Figure 38:** Service screen

The Auto Nozzle option is activated by pressing the button [3L]. On machines with this option installed and enabled, nozzles will automatically be selected as the telescoping spray bar is extended, and they will be deselected as the bar is retracted. This prevents accidental missed coverage and spraying in front of the paver's wheels or tracks.

The troubleshooting sequence is accessed by pressing the button [4L]. It initiates a sequence that automatically runs the spray system through modes and collects diagnostic data.

Real-time sensor data can be viewed on the System Data screen by pressing the button [4R].

### System Data Screen

Your Integral dx Spray Paver (purchased after 2020) comes equipped with various sensors incorporated for machine monitoring and troubleshooting. Information given on this screen, shown in Figure 39, can confirm parameters are running correctly or help identify problems in the system.

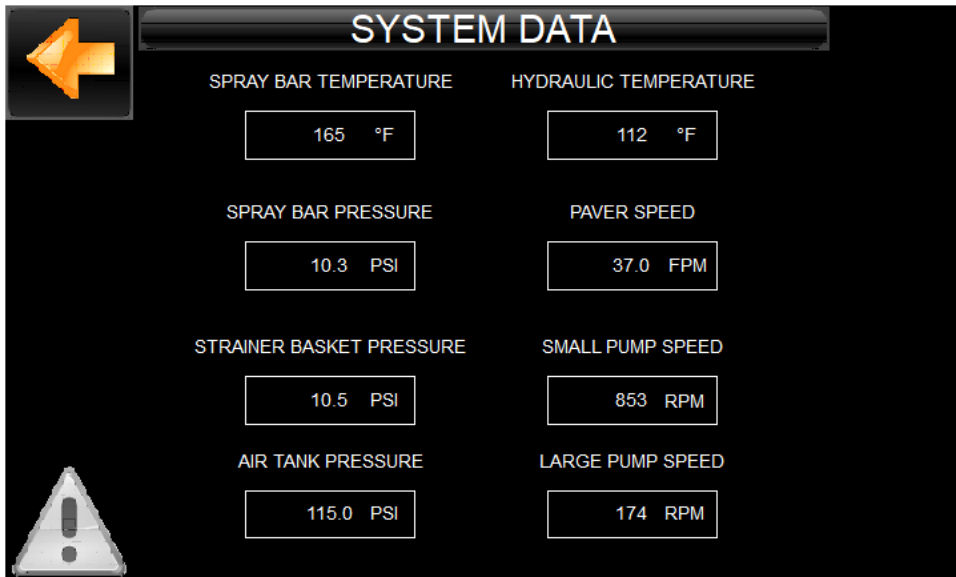

Figure 39: System Data screen

## Troubleshoot Sequence

A troubleshooting sequence has been incorporated into the Spray Paver's control system for the purposes of machine monitoring and troubleshooting. It was designed to run through the different Pump Functions and record data during this process in order to output to a file for review to aid in evaluating machine performance.

Follow the steps below to conduct a Troubleshoot Sequence and output data.

### 1) Start the Sequence

If your Spray Paver is running software version V4.1 (released in 2020), or above, navigate to the Service Screen, then locate and press the button associated with the icon shown below [4L].



**Figure 40: Troubleshoot Sequence Icon**

The screen will then prompt with a Yes/No/Cancel option. Select the option described below that is most appropriate.

**Table 6: Troubleshoot Sequence Prompt 1**

Yes	The sequence will run in full, and will spray hot emulsion out of the spray bars.
No	The sequence will run in full, but will not spray hot emulsion out of the spray bars.
Cancel	The sequence will abort and return to the Service Screen.

If Yes or No is selected from above, a second screen will prompt the user to confirm this selection. The result of the options are described below.

**Table 7: Troubleshoot Sequence Prompt 2**

Yes	Sequence confirmed. Troubleshoot Sequence will begin immediately.
No	Sequence canceled. Return to Prompt 1
Cancel	Sequence canceled. Exit Troubleshoot. Return to the Service Screen

## 2) Run the Sequence

Once “Yes” is selected to the confirmation prompt (Prompt 2) the machine will immediately begin the Troubleshoot Sequence. The display shows the progress of the Troubleshoot Sequence.

At step 6, if the sequence was initiated by requesting hot emulsion spray from the spray bars, a prompt will ask the user to make sure no personnel are near the spray bars before the hot emulsion starts to spray from the nozzles. The results to this prompt are described in the table below.

**Table 8: Troubleshoot Sequence Prompt 3**

Yes	Continue to run with spray. WARNING. Hot emulsion will spray from the center spray bar
No	The sequence will continue without spray
Cancel	The sequence will cancel and return the user to Prompt 1

## 3) Write the Troubleshooting Sequence Data to File

Once the sequence has been run in full it will reach step 10 on the display and prompt the response: “Press button to create log file.” The results of the button options are described below.

**Table 9: Troubleshoot Sequence Prompt 4**

Create Log File	The sequence data will begin compiling to an output .csv file.
Cancel	Sequence data will be retained for the Idx App, but will not create the .csv file. User will be returned to the Service screen.

## 4) Send the Data File to your Integral dx Representative

There are two options for exporting the troubleshooting data.

**Option 1** – Download the data to your Android device using the Integral dx App (IOS not supported). Once all the data has been downloaded (this process can take 5-10 minutes) the App will automatically initiate an email and will prompt that it be sent directly to the Integral dx representatives with the in-app created .csv file attached.

Contact your Integral dx representative or dealer with any questions.

**Option 2** – Export the .csv file to a USB memory stick following the process in the next section. Then send the file your local Integral dx distributor or directly to your Integral dx Representative through email or by sending the memory stick.

### **Saving Data onto a USB Memory Stick**

After completing the troubleshooting sequence, the screen shown in Figure 41 will be displayed.



**Figure 41:** Final screen of troubleshooting sequence.

Press the 'Create Log File' button [1R] to create a .csv file containing the data collected during the troubleshoot sequence. Once all the data has been written to the file, the display will show the screen in Figure 42.



**Figure 42:** Log file has been created.

Figure 43 shows the location of the USB port on the back of the display. Carefully remove the cover; be sure to retain the two screws and seals.

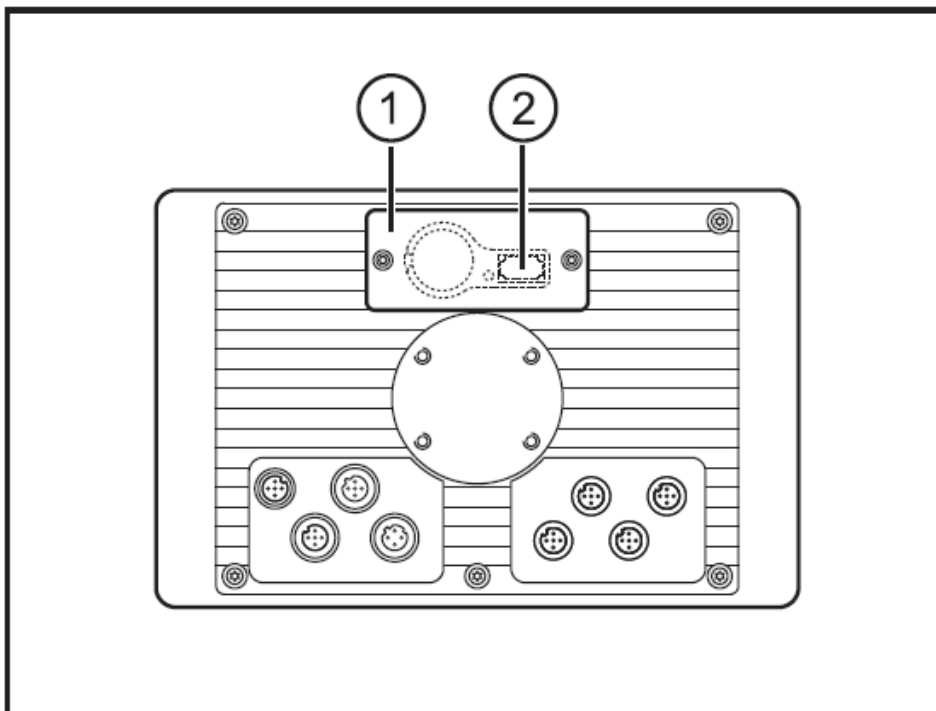

- 1: service cover
- 2: USB socket, type A

**Figure 43:** Location of USB port on display.



Insert the USB memory stick into the USB port on the display. It will automatically recognize that a memory stick has been inserted and will show the screen in Figure 44.

**\*\*Disclaimer: The display unit may not be compatible with all USB memory sticks.\*\***



**Figure 44:** Screen recognizing insertion of a USB memory stick.

Press the 'log file transfer' button [2R]. If the USB memory stick is compatible with the display and the display has successfully transferred the file to the USB memory stick, it will show "Copy Complete."

Press the 'Remove USB' button [3R] in order to safely remove the USB memory stick without data corruption. Once it is safe to remove the memory stick, the screen will show "Safe to Remove USB". Then remove the memory stick and replace the sealing cover on the back of the display. The display will return to the 'Create Log File' screen. Press the 'Cancel' button [1L] to exit the troubleshooting function. If a warning appears that data will be lost, you can disregard it and press 'Cancel' again. The data has been saved to the USB stick and will be removed from the display's internal memory.

## Auto-Nozzle Option

An option was created for automatic actuation of spray nozzles. If this option is installed, the hydraulic cylinders for spray bar extension have internal sensors which provide feedback of the spray bar's travel throughout its stroke in order to determine where each nozzle is selected.

Look for this icon on the Service screen to turn auto-nozzle actuation on/off [3L].



**Figure 45:** Auto nozzle ON/OFF icon

Each time this option is turned on a message on the screen will appear asking the operator if they would like to calibrate.

Yes	This will present the nozzle calibration page
No	Existing calibration values will be used, Auto Nozzle actuation has been turned ON

Initial calibration is done at the factory and the operator should not need to make any changes.

## Auto-Nozzle Calibration

If 'Yes' is selected from the previous step, it will present the screen in Figure 46 below.

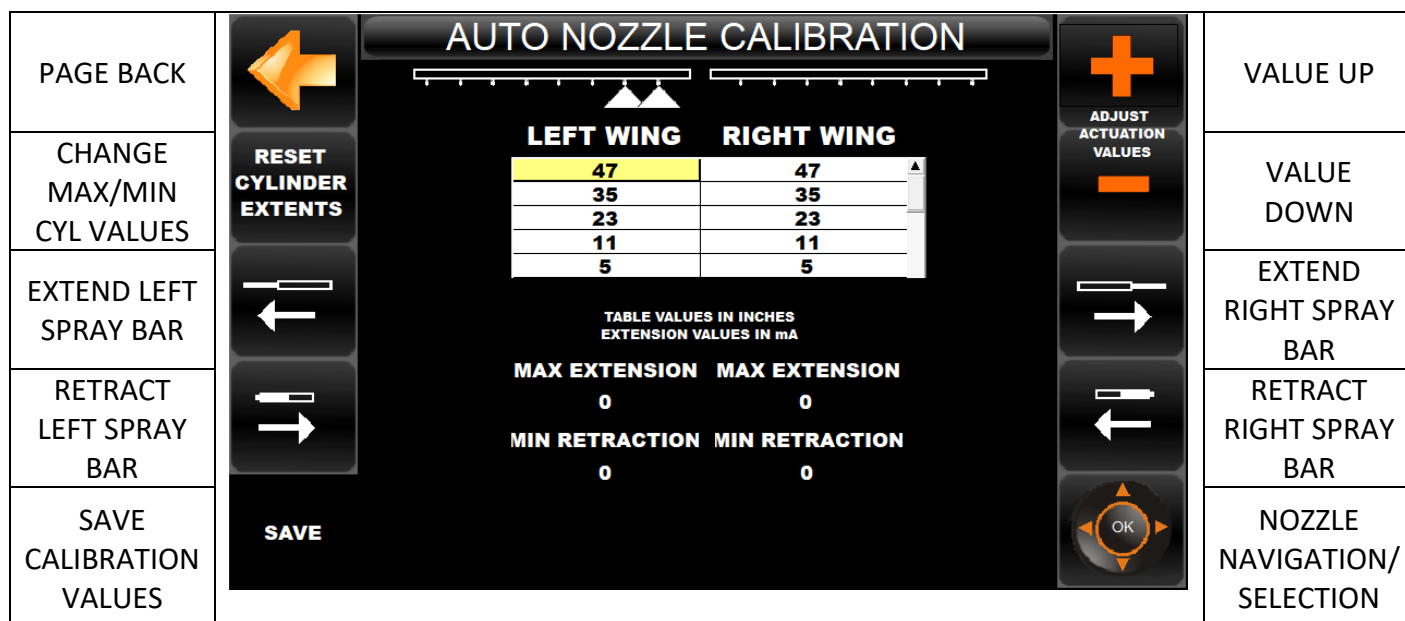

Figure 46: Auto nozzle calibration screen

The table shows actuation values of each nozzle/gang. Navigate the table with the navigation button [5R] and then push the center 'OK' button to select the value for a particular actuator. Once selected use the '+' or '-' button [1R] or [2R] to adjust the values in ¼" increments. Once the value has been adjusted, hit the 'OK' button again and continue making adjustments to other actuators until complete. Once complete, save the new values by pushing the save button, [5L]. These new values will be kept until calibration changes are made again in the future.

Under various circumstances (mainly age/use) the cylinders may become out of sync with the control system. If this is the case, reset the cylinder extents [2L]. The extension/retraction values will change. Simply extend both left and right cylinders separately until the control system reads the maximum value for that cylinder. Once the maximum extended value has been reached, fully retract the cylinder until it is at minimum stroke. Once the values stop changing on the display, the max and min values have been determined. Hit the 'save' button [5L] to save these new values to controller memory.

## Alarms screen

The alarms screen (Figure 47) displays automatically when there is an alarm condition. If more than one error conditions exist, the screen will cycle through the error messages.

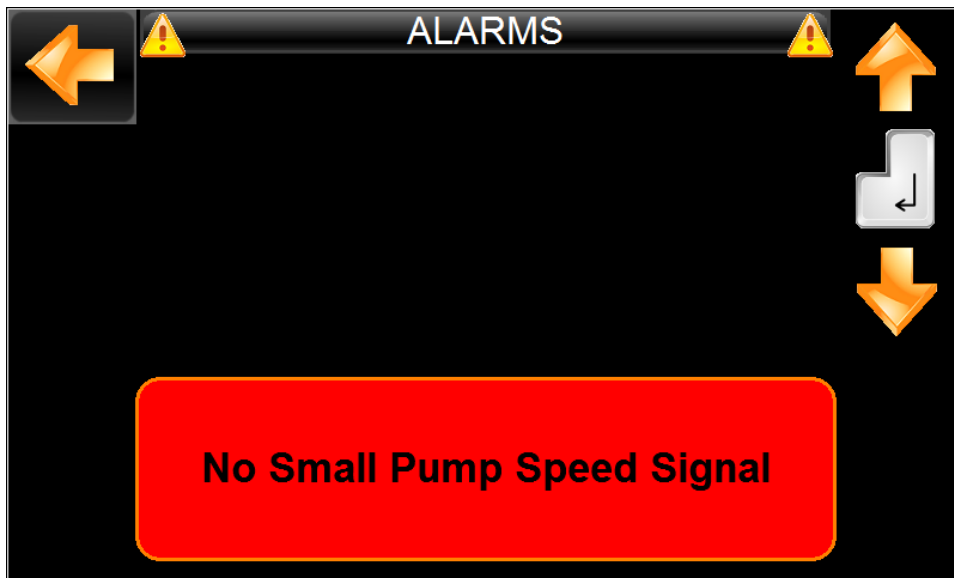

**Figure 47:** Alarms screen

On other screens, the warning symbol on the lower left will turn yellow if there is an active alarm.

- Press key [1L] to exit the alarm screen.
- From other screens, press key [5L] to go to the alarm screen and see the error condition.

The following error conditions are displayed on the alarm screen:

**Low air pressure:** The pneumatic system has low air pressure.

If the air pressure in the reservoir reaches a certain low-level threshold, the low air alarm will display warning the operator. If the air pressure reaches a critically low level, a critically low air alarm will display. This occurs at the minimum air pressure that will actuate valves in the spray system. If the air drops any lower, the machine will be unable to close any valves that are open.

In Spray Auto, the critically low air alarm will display a 20-second countdown: “Nozzles will deactivate in # seconds. Disable spray nozzles?”

- Press key [1R] **Yes** to skip the remainder of the timer and close the spray valves immediately.
- Press Key [3R] **No** to continue operation as normal but with the added risk of not being able to close the nozzles.
- If no button is pressed, the spray nozzles will automatically close when the timer reaches 0.

In all other pump functions or if no pump function is selected, the alarm will display “Warning, low air pressure,” until the air pressure is within the operating range.

 **Note:** During startup, air pressure is building up, so there is a delay before a low air pressure warning can become active.

**No small pump speed signal:** The small pump is not turning or there is a problem with the sensor wiring on the hydraulic motor. Ensure the hydraulic drive motor and pump are not seized. Check the wiring to the sensor on the motor. When the problem is corrected and the pump is running, the warning will automatically clear.

**No large pump speed signal:** This alarm is only active in spray auto mode when the flow rate is high enough to require the large pump is active. The large pump is not turning or there is a problem with the sensor wiring on the hydraulic motor. Ensure the hydraulic drive motor and pump are not seized. Check the wiring to the sensor on the motor. When the problem is corrected and the pump is running, the warning will automatically clear.

**Hydraulic Oil over Temperature:** The temperature of the hydraulic oil in the tank rises above the preset temperature.

## Spray paving steps

There are six basic sequential steps to spray paving (details of each step are described below):

1. Load emulsion in the tank(s): Fills the tanks with emulsion (page 88)
2. Circulate the tank(s): Heats up the pumps and valves before spraying (page 94)
3. Circulate the spray bar: Heats and charges the spray bars before spraying and prevents emulsion cooling and clogging when spraying is paused (page 95)
4. Spray emulsion: Applies emulsion to the paving surface (page 96)
5. Vacuum the spray bars: Pulls emulsion back in the tank when spraying is complete (page 98)
6. Clean out and rinse the spray bars: Cleans the system after use to prevent clogging (page 99)

## Loading emulsion in the tank(s)



**Warning:** Wear protective gear for face, hands, feet and body when working with hot material.



**Warning:** Take extra care when cutback emulsions are used. They have a much lower flash point thereby posing a greater risk of explosion. Verify maximum temperature allowed of product and spray paver before heating.



**Warning:** Do not mix different asphalt emulsion materials in the tank. Clean tank and the circulating system before adding a different substance.



**Warning:** Asphalt emulsion is a water base product. As such it will boil at 212° F, causing steam inside pipes and possibly resulting in an explosion. Keep emulsion from boiling.



**Danger:** When working around asphalt emulsion, first you must immediately be aware of the danger of steam explosions. Second, you must consider you are near a hot material that can burn skin, eyes, face, & hands. Always be aware of the position of hoses you are handling relative to yourself and those around you and the hot material inside.



**Danger:** Handle emulsion with care. It can be highly flammable. Do not overfill the tank. Expansion and spillage creates a fire hazard. Clean up spilled emulsion before operating the machine. A spark could ignite the spillage.





**Danger:** Do not smoke while loading the machine. Do not load the machine near open flame or sparks. Death or serious injury will occur from explosion or fire.



**Danger:** Fill tank outdoors to reduce the chance of fumes accumulating and causing a fire or explosion. Prevent fires by keeping machine clean of accumulated grease and debris.



**Danger:** Do not fill tank to absolute capacity. To reduce the risk of expansion and spilling from the tank, allow a minimum of 10 percent of the tank capacity for expansion.



**Danger:** Before loading new hot emulsion, diesel or release agent left in piping and emulsion pumps from prior clean out needs to be vacuumed back and discarded so hot emulsion does not come in contact with a cold liquid that can steam and explode.

Loading emulsion can be done in three ways:

- Connect to load coupler and use the spray paver pump.
- Connect to load coupler or tank drain, and use the transport system pump
- Load through the top of the tank



**Tip:** To prevent clogging, load emulsion heated to 170° F.

## Connecting to load coupler and using the spray paver pump

The load line can be connected to the load coupler on the pumping station, and the spray paver system can use its own pump to pump material into the tank.

The schematic in the Appendix 1 (page 136) shows the pump group valving when the display screen unit is set to Tank Load

1. Connect the load line to the load coupler on the pumping station.
2. If the system has more than one emulsion tank, select the tank using the tank selector switch on the main control box.
3. Select **Pump Function>Tank Load**, activate the pump, and set the rate. The large spray paver pump is used for loading.
4. Open the manual valves on the load coupler, the load line, and the transport.
5. Increase the pump speed as desired. When the first tank is full, use the tank select switch to load additional tanks as necessary.
6. Stop the pump when the tank is at the desired level.
7. Shut off the valve on the transport.
8. Open the air vent near the transport side to allow the load line to be vacuumed out.
9. Close the valve on the load coupler, turn off the pump, and disconnect the load line.
10. Replace the load line cap on the spray paver.
11. Soon after loading, select **Pump Function>Tank Circulate**, activate the pump, and set the rate. This keeps hot emulsion moving in the lines.

## **Connecting to load coupler or tank drain and using the transport system pump**

If the supply tank has its own pump, it can pump material into the emulsion tank. Make the connection either to load coupler on the pump station or directly to the tank drain.

Pump station connection:

1. Connect the load line to the load coupler on the pumping station.
2. Select **Pump Function>Tank Circulate**, activate the pump, and set the rate.
3. Open the manual valves on the load line, spray paver and transport.
4. Shut off the transport pump when the desired level is achieved.
5. Shut off the valve on the spray paver.
6. Run the transport pump in reverse at a lower setting.
7. Open the air vent near spray paver side to allow load line to be vacuumed out.
8. Close the transport valves, turn off the transport pump, and disconnect.
9. Replace the load line cap on the spray paver.
10. Soon after loading, select **Pump Function>Tank Circulate**, activate the pump, and set the rate. This keeps hot emulsion moving in the lines.

Tank drain connection:

1. Connect the load line to the spray paver tank drain.
2. Open the manual valves on the load line and tank drain.
3. Shut off the transport pump when the desired level is achieved.
4. Shut off the valve on the spray paver.
5. Run the transport pump in reverse at a lower setting.
6. Open the air vent near spray paver side to allow load line to be vacuumed out.
7. Close the transport valves, turn off the pump, and disconnect.
8. Select **Pump Function>Tank Circulate**, activate the pump, and set the rate. This keeps hot emulsion moving in the lines.

## Load in the top of the tank

The top lids on the emulsion tanks (see Figure 48) can be removed and liquid pumped directly into the tanks.



**Warning:** Splashing hot emulsion from the top of the tank is dangerous to bystanders below.



**Avoid damage:** Monitor the tank level indicator to ensure the tank does not overflow, but note that the float level can be stuck from prior use.

1. Unbolt the lid, and remove it from the top of the tank.
2. Select **Pump Function> Tank Circulate**, activate the pump, and set the rate.
3. Keep the strainer basket in the tank in place.
4. Pour emulsion into the lid.
5. When loading is complete, replace and bolt down the lid.
6. Soon after loading, select **Pump Function>Tank Circulate**, activate the pump, and set the rate. This keeps hot emulsion moving in the lines.

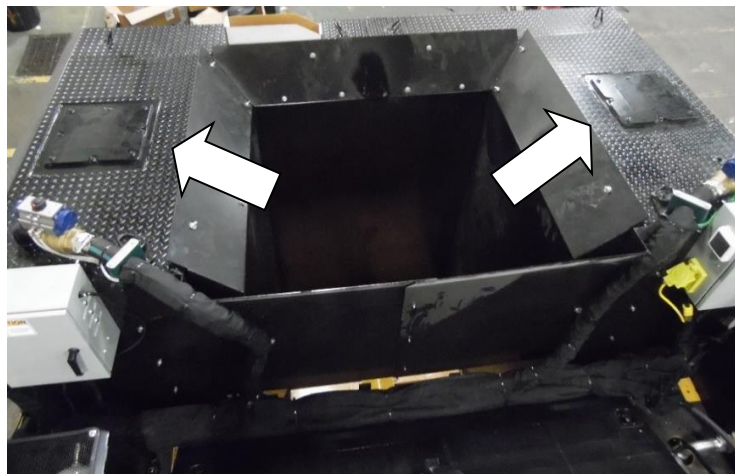

**Figure 48:** Emulsion tank top lid

## Circulating the tank

Use Tank Circulate to heat up the emulsion pumps and pump group piping before spraying and keep the emulsion mixed. The type of emulsion affects the time required for tank circulating, but typically 5 to 7 minutes is needed.

The schematic in the Appendix 1 (page 137) shows the pump group valving when the display screen unit is set to Tank Circulate.



**Note:** Never skip circulating the tank as the cold piping can cool down the emulsion and cause clogging.

To circulate the tank, select **Pump Function>Tank Circulate**, activate the pump, and set the rate. Run for 5 minutes.

## Circulating the spray bar

Use Spray Bar Circulate to do the following:

- Heat all the piping of the five sections of the spray bar to prevent clogging.
- Charge the piping, filling it with emulsion for spray application.

The schematic in the Appendix 2 (page 138) shows the pump group valving when the functional display unit is set to Spray Bar Circulate.



**Warning:** Never allow hot emulsion to come in contact with water in the spray bar piping or steam and explosion can occur.



**Note:** Never skip circulating the spray bar as the cold piping can cool down the emulsion and cause clogging.

To circulate the spray bar, select **Pump Function>Spray Bar Circulate**, activate the pump, and set the rate. Run for 5 minutes initially.

## Spraying emulsion

Spraying a specific amount of emulsion on the pavement surface is the purpose of the spray paver. When Spray Auto is selected, the emulsion pump will turn slightly to pre-pressurize the spray bar system, so that immediate application occurs when the master power switch on the pendant control is selected.

The schematic in the Appendix 2 (page 139) shows the pump group valving when the display screen unit is set to Spray Auto.

### Using the spray bars

 **Note:** See page 33 for adjusting the spray nozzles.

1. Use the Sprayer Selection screen to extend the telescoping spray bars to the screed width, tilt the front spray bar down, and select spray nozzles.
2. Select **Pump Function>Spray Auto**, activate the pump, and set the application rate
3. Turn on the master spray switch on the pendant control to start spraying.
4. When the paver stops, the “Turn off the master switch!” will appear. Turn off the master spray switch to prevent the emulsion from draining through the nozzles.

 **Tip:** Starts and stops during spraying occur many times on a job site. If another spray application is not going to be started within a few minutes, select Pump function>Spray Bar Circulate. This prevents emulsion from cooling down and clogging the piping.





**Note:** While operating in the Spray Auto function under standard conditions, all emulsion passing through the emulsion pump flows through the spray nozzles. Bypassing emulsion is not possible unless a control valve for the pumping station malfunctions or the pump outlet pressure exceeds the pump bypass set point of 80 psi (5.5 bar), which is about five times the typical spraying pressure.

### Using the spray wand

1. Select **Pump Function>Spray Auto**, and activate the pump.
2. Use an arc spraying motion to coat the surface until the desired coverage is reached.



**Tip:** If the master spray switch on the pendant is off, there will be higher pressure to the spray wand because the pump runs at a fixed speed to build pressure within the spray bars. If the master spray switch is on, the spray wand will operate at a lower pressure, and coverage will be below the set amount.

## Vacuuming back emulsion

When spraying is complete, and the system is going to be idled for several minutes (without spray bar circulation) or overnight, use the Spray Bar Vacuum function to pull emulsion in the piping back to the emulsion tank.

The schematic in the Appendix 2 (page 140) shows the pump group valving when the display screen unit is set to Spray Bar Vacuum.

1. Select **Pump Function>Spray Bar Vacuum**.
2. Select the **Center** spray bar section.
3. Activate the pump. The pump rate is fixed.
4. Run the pump for about 30 seconds to build system pressure.
5. Turn on the master spray switch for 3 minutes. This opens the spray nozzles, allowing air to flow backwards through them to clear emulsion.
6. Select the **Left Front-Right Front** (telescoping) spray bars. Repeat steps 4 to 5, turn on master spray switch for 1 minute.
7. Select the **Left Rear-Right Rear** spray bars.
8. Run the pump for about 30 seconds.
9. Turn on the master spray switch for 3 minutes.
10. Turn off the master spray switch, turn off the pump, and proceed to cleaning out and rinsing.

## Cleaning out and rinsing

The remaining residual emulsion must be broken down using a release agent, which is stored in the clean out tank. Do this by circulating release agent through all piping and pumps, and leaving the release agent in place when parking overnight or for prolonged storage.



**Tip:** To prevent nozzle clogging, remove the nozzles at the end of each day, and soak them in release agent.

The schematic in the Appendix 2 (page 141) shows the pump group valving when the display screen unit is set to Clean Out.

### Cleaning out the spray bar

1. Ensure the clean out tank has adequate release agent.
2. Open the manual ball valve at the clean out tank (see Figure 49).
3. Select **Pump Function>Clean Out**, and activate the pump. If more suction is needed to draw fluid from the cleanout tank, run the pump at high rate for a short period of time.
4. Run the pump to fill the spray bar with release agent. Use a low pump rate of 50% or less.
5. To flush the spray nozzles with release agent, select the desired nozzles on the Spray Nozzle Selection screen, and turn on the master spray switch.
6. Turn off the master spray switch when flushing the nozzles is complete.
7. After stopping the pumps, close the manual ball valve at the clean out tank. Note: newer systems have an automatic valve to shut off flow from the cleanout tank; on these, it is not necessary to close the manual ball valve.



**Figure 49:** Clean out tank manual ball valve

## Draining the emulsion tank

Completely empty the emulsion tanks at the end of the day as follows:

1. Open the valve on the bottom of the tank.
2. Drain the contents into an approved container.
3. Dispose of the material according to local, state, and federal regulations.



**Note:** If emulsion types are changed, clean the tank as some types of emulsion are not compatible with others.



**Avoid damage:** If the tank is going to be stored for a period of time, clean it, and coat it with a rust prevention fluid.

# Maintenance

## Recommended spare parts

Part number	Description	Quantity
<b>Spray bar components</b>		
IDX23011	CYLINDER, PNEU, 1-1/16 X 2	1
IDX23013	ROTARY ACTUATOR, PNEU	1
IDX23081	ASSY, VALVE, SHORT, SPRAYBAR (center)	1
IDX23075	ASSY, VALVE, OUTER, SPRAYBAR (outer wing)	1
IDX23079	ASSY, VALVE, LONG, SPRAYBAR (inner wing)	1
IDX10517	CLEVIS PIN, ½" DIA	2
<b>Emulsion hose</b>		
IDX11040	HOSE, 0.75" SUCTION - 12 GMV (rear spray bars & spray wand)	splice kit
IDX11170	HOSE, 1" SUCTION - 16 GMV (to spray bars)	splice kit
IDX10968	HOSE, 2" SUCTION - 32 GMV (to tanks)	splice kit
IDX11179	HOSE CLAMP, 1.5"ID T-BOLT (spray bar)	10
IDX10972	HOSE CLMP, T BOLT 2 5/16-2 5/8 (tank supply, return)	10
IDX10448	T-BOLT HOSE CLAMP (for 1.5" hose in pump station)	5
IDX23334	HOSE CLAMP, 1.25" (rear spray bar and pump station)	5
<b>Hydraulic &amp; Emulsion General</b>		
IDX22036	SCREEN, 1/16" HOLES	1
IDX10018	ASPHALT PUMP, 20 GPM	1
IDX23045	GASKET, END CAP	4
IDX10122	GASKET, SCREEN BASKET	2
<b>Pneumatics</b>		
IDX10866	TUBING, 1/4"OD BLK 1000' REEL	25 ft.
IDX11050	FITTING ,AIR 1/4 UNION (push-in splice)	2
IDX20780	VALVE ONLY, PNEUMATIC SINGLE	1
IDX20779	KIT, GASKET & 2 SCREWS (for valve IDX20780)	1
IDX11031	AIR FILTER, COMPRESSOR	2
IDX20701	COMPRESSOR, 24 V	1
<b>Spray nozzles</b>		
IDX23452-06	SPRAY NOZZLE 06 CAPACITY	40
IDX23452-08	SPRAY NOZZLE 08 CAPACITY	40
IDX23452-10	SPRAY NOZZLE 10 CAPACITY	40
<b>Electrical</b>		
IDX10791	ATC AUTOMOTIVE FUSE 10 AMP	4
IDX20586	FUSE, 30A MAXI (Air compressor)	2

**Table 10:** Recommended spare parts

## Service interval

Task	Ref. page	Frequency			
		As required	Every day	Every week	Every year or 400 hours
Clean the spray wand.	106	X			
Clean the machine.	106	X			
Clean the strainer screen in the pumping station.	107	X			
Check the hydraulic oil level.	108		X		
Inspect hydraulic hoses and emulsion hoses.	108		X		
Check the fluid level in the clean out tank.	108		X		
Clean blockage from the emulsion tank overflow tubes.	108		X		
Clean the hydraulic cylinder rods.	109		X		
Drain the air compressor tank and air filter.	109		X		
Open and drain tank sump	110		X		
Inspect the packing gland on the emulsion pumps.	109			X	
Inspect the emulsion pump coupler.	111			X	
Lubricate the emulsion pump bearings	111			X	
Inspect the packing gland on the emulsion tank.	111			X	
Check the tightness of the tank tie-down hardware.	111			X	
Check the spray bar hardware.	111			X	
Check the condition of the hydraulic filter.	112			X	
Check oil level in the compressed air oiler.	112			X	
Change the hydraulic oil and filter.	112				X
Change the fluid in the clean out and fuel tank.	113				X
Replace engine air filter element.	113				X

**Table 11:** Service intervals

## Routine maintenance procedures



**Warning:** Do not attempt repairs unless properly trained to do so. Refer to manuals and experienced repair personnel for assistance.



**Warning:** Do not service the machine while it is in motion or while the engine is running. If the engine must be running to service a component, apply parking brake, block wheels, and use extreme caution.



**Warning:** Allow machine to cool as necessary before repairing or servicing working components.



**Warning:** Wear protective glasses and other required safety equipment when servicing or repairing the machine.



**Warning:** Follow good shop practices: Keep service area clean and dry. Be sure electrical outlets and tools are properly grounded. Use adequate light for the job at hand.



**Warning:** Clear the area of bystanders when carrying out any maintenance, repairs, or adjustments.



**Warning:** Support the machine with blocks or safety stands when working beneath it. Death or serious injury can result from the machine falling off a jack and crushing you.





**Warning:** Keep hands, feet, hair, and clothing away from moving parts. Death or serious injury can occur from entanglement in moving parts.



**Warning:** Do not make repairs on pressurized components until the pressure has been properly released. Use extreme caution when working on hot or pressurized plumbing.



**Danger:** Do not make repairs using tape, clamps, or cements. The hydraulic system operates under extremely high pressure. Such repairs will fail suddenly and create a hazardous condition.



**Warning:** Before applying pressure to a hydraulic system, be sure all lines, fittings, and couplers are tight and in good condition. Leaking fittings are a fire hazard. Hydraulic fluid under pressure can pierce skin, resulting in serious injury or toxic reaction. Do not feel for hydraulic leaks with your hands.



**Warning:** After servicing, make sure all guards are in place and properly secured. Serious injury can occur from being caught in unguarded moving parts.



**Warning:** After servicing, be sure that all tools and parts or servicing equipment are removed from the unit. Loose equipment left in the machine can get caught in moving components and cause injury or equipment damage.

## Cleaning the spray wand

After using the spray wand, it is critical to clean it because if liquid emulsion is allowed to cool within the hose and wand, it will not be useable. Clean as follows:

1. Select **Pump Function>Spray Bar Vacuum**. The spray bar vacuum page will appear where one of the five spray bar sections needs to be selected.
2. After running the Spray Bar Vacuum function on these sections for 30 seconds to 1 minute, open the ball valve of the spray wand to allow air to be sucked in.
3. Place the spray wand nozzle into a container of release agent and vacuum a gallon of release agent.
4. Remove the spray wand nozzle from the release agent container to suck in air leaving the spray wand and hose empty.
5. Turn off spray bar vacuum pump function.
6. Remove the spray wand quick disconnect from the emulsion pumping station.

## Cleaning the machine



**Warning:** Take care during cleaning operations to avoid electrical shock. A wet or damp electrical component may cause a dysfunction in the machine or a short circuit in the electronic system. Only clean the unit after all power has been switched off. Do not use a pressure washer.

- To protect the environment and prevent oxidation to the machine, only use ecological cleaning products with a neutral PH and that have no danger to the skin.
- Use cleaning rags. Do not use abrasive equipment (no scrapers).

## Cleaning the strainer screen in the pumping station

1. Remove the cover from the pumping station.
2. Unbolt and remove the strainer housing lid. (Lid can be pried off using tabs, or bolts threaded into holes to push lid off)
3. Pull out the strainer screen (Figure 50).
4. Manually remove debris or rinse. Use an appropriate solvent or release agent.
5. Replace the screen, lid and pumping station cover.

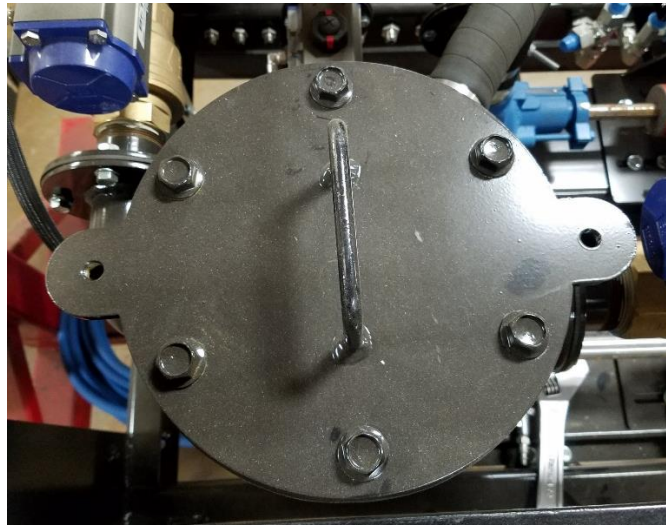

**Figure 50:** Strainer screen in the pumping station

## Checking the hydraulic oil level

1. When hydraulic oil is cool, the oil level should be visible at the bottom of the sight glass but no higher than halfway up the sight gauge.
2. If additional hydraulic oil is needed, fill with CAT HYDO Advanced 10 hydraulic oil.

## Inspecting hydraulic hoses and emulsion hoses



**Warning:** Hydraulic oil under pressure is a skin injection hazard and can cause serious injury or death. Do NOT use your hands or other body parts to check for leaks. If hydraulic oil is injected under the skin, it can cause gangrene. Seek medical help immediately.

1. Use a piece of cardboard to check for hydraulic and emulsion hose leaks. Also check the following:
  - The tightness of the whole system.
  - The hoses for unwinding, points of friction, crushing, cracks, porosity, etc.
2. Tighten any loose connections, and replace any damaged hoses.

## Checking the fluid level in the clean out tank

Use sight glass on the tank (if equipped) or look into the fill cap opening using a flashlight.

## Cleaning blockage from the emulsion tank overflow tubes

1. Use a long narrow tool to clear the tubes.
2. Use an appropriate solvent or release agent to further clean the tubes.

## Cleaning the hydraulic cylinder rods

With the telescoping cylinders fully extended, use an appropriate solvent or release agent and soft rags to wipe the cylinder rods.

## Draining the air compressor tank and air filter

1. Open the drain valve for the compressed air tanks to drain any water condensate. (Figure 51)
2. Open the drain valve to drain the compressed air filter. (Figure 45a)
3. Remove air filter from compressor pump and clean or replace if needed. (Figure 52)

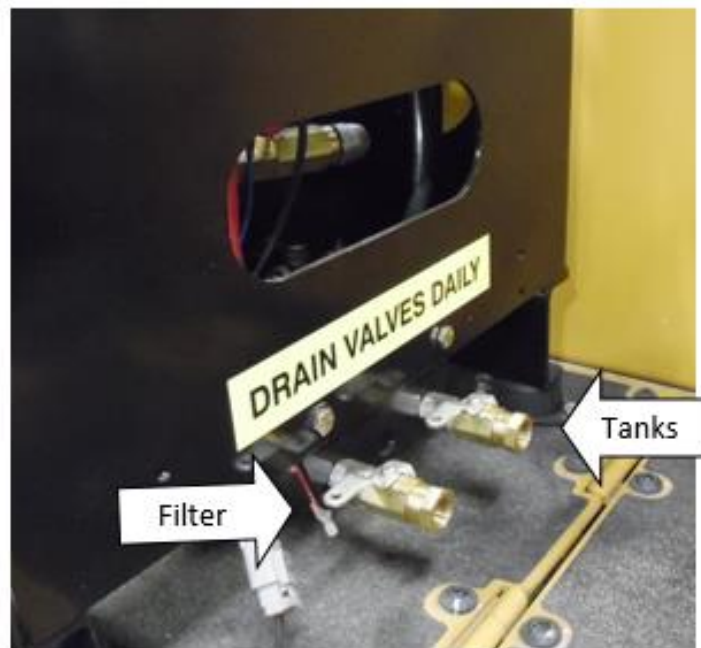

**Figure 51:** Drain valves for air tanks and filter.



**Figure 52:** Air filter on compressor.

### **Draining the emulsion tank sump**

1. Open the emulsion tank final drain.
2. Leave open for a few minutes until debris quits coming out.
3. Close drain.

### **Inspecting the packing gland on the emulsion pumps**

Inspect for leaking below the pump. If there is leaking, tighten the packing gland nuts (located near the driveshaft, see Figure 53) until leaking at the driveshaft is no longer observed. Do not over tighten.

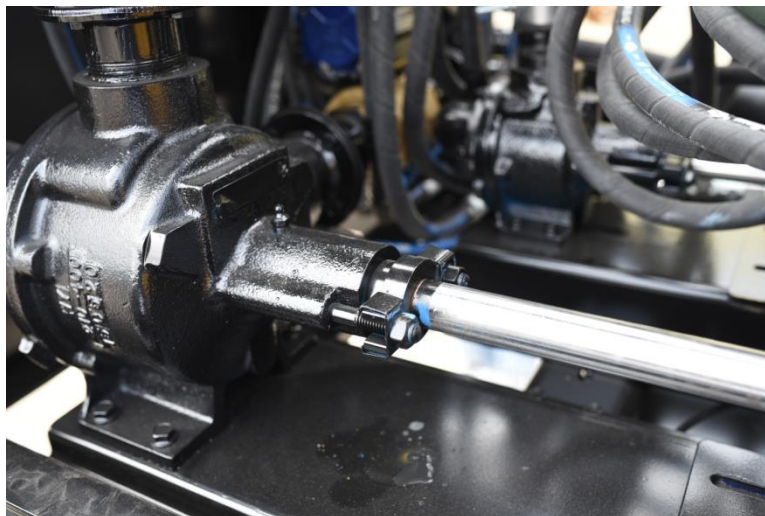

**Figure 53:** Emulsion pump packing gland nuts

## **Inspecting the emulsion pump coupler**

On each emulsion pump, check the tightness of the coupler set screws. If they are loose, remove them, brush Loctite 242 on the threads, and tighten.

## **Lubricating the emulsion pump bearings**

1. Use a grease gun to grease the zerk on the large emulsion pump (the small pump does not have a grease zerk).
2. Wipe away excess grease.

## **Inspecting the packing gland on the emulsion tank**

Check for leaks around the sight gauge. If there are leaks, remove the sight gauge, and tighten the nut until leaking stops.

## **Checking the tightness of the tank tie-down hardware**

Examine the bolts that hold the tanks to the paver hopper. Make sure they are tight and secure.

## **Checking spray nozzle alignment**

1. View the spray pattern to see if all nozzles spray at the same angle.
2. Set nozzles as shown in Figure 9.

## **Checking the spray bar hardware**

1. Make sure bolts are tight.
2. Make sure actuators and linkages operate freely and are not worn.
3. Make sure valves open and close correctly.

## Checking the condition of the hydraulic filter

1. Look at the hydraulic filter cleanliness indicator, which is found on the hydraulic filter housing.
2. Change the filter as necessary by twisting off the filter cover, replacing the filter and reinstalling the cover.

## Removing debris in the emulsion tank sump

1. Open the emulsion tank drain.
2. Power wash the tank interior.
3. To prevent rusting, coat the tank interior with a film of rust preventative.

## Checking oil in the compressed air oiler

1. Look at the oil level of the air lubricator in the sight gauge on the side of the air compressor unit (Figure 54).
2. If oil needs to be added, remove the compressor unit cover, fill the lubricator with standard air tool oil, and replace the cover.



**Figure 54:** Air lubricator sight gauge location.



## **Changing the hydraulic oil and filter**

1. Place a container with a capacity as large as the hydraulic reservoir under the hydraulic reservoir drain plug, which is located on the bottom rear of the reservoir.
2. Remove the plug from the end of the drain, and open the ball valve to drain the hydraulic oil. When the oil is drained, remove the container.
3. Close the ball valve, and reattach the plug.
4. Change the filter by twisting off the filter cover, replacing the filter and reinstalling the cover.
5. Remove the tank cap, and fill the hydraulic reservoir up to the sight glass (but not more than  $\frac{1}{2}$  way up the sight glass when cold) with Cat HYDO Advanced 10 hydraulic oil (Part number IDX 10985). Replace the cap.

## **Changing the fluid in the clean out tank**

If the fluid in the clean out tank was not drained at the end of the previous season, change it as follows:

1. Drain fluid.
2. Fill with new.

## **Replacing the engine air filter element.**

Refer to the service manual for your specific paver, and follow its instructions for replacing the engine air filter.

## **Calibrating the small asphalt pump**

1. Verify that there are no leaks on the emulsion system.
2. With the paver parked on a level surface and the asphalt emulsion tank nearly full, take a dipstick reading and use the specific table for your paver in the Appendix 4: Emulsion tank configuration (page 151) to determine the volume of fluid in the tank.

**Note:** When measuring fluid level with the dipstick, place the dipstick into its bore, but DO NOT thread the dipstick into the bore.

3. In the Totals screen of the display screen unit, zero the job totals by holding down the circular arrow key [2R] (see Figure 55) for at least 5 seconds.

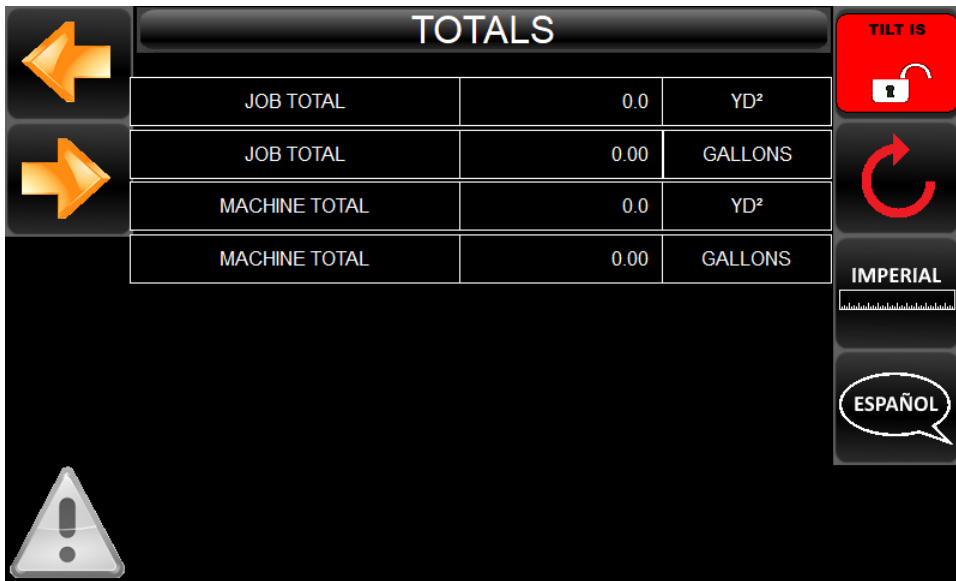

**Figure 55:** Zeroing the job totals

4. Begin spraying in the Spay Auto mode. Continue until the tank gets low. Be sure to not run the tank too low, or a dipstick measurement will not be possible. Stop and start spraying as necessary during this process to check the tank level.
5. With the paver parked on a level surface, use the emulsion tank dipstick to measure the volume of fluid in the tank. Use the tables in Appendix 4: Emulsion tank configuration to determine the amount of emulsion in the tank from the dipstick value.

**Note:** Measure the fluid level with the dipstick placed in the bore, but do not thread the dipstick into the bore.

6. In the Totals screen of the display screen unit, note the Job Total volume (gallons or liters).
7. Calculate the Small Pump Calibration Factor.

$$\frac{(Start\ Volume - End\ Volume) (Old\ Calibration\ Factor)}{Job\ Total} = Calibration\ Factor$$

8. On the Password screen of the display screen unit, enter the password. The Service screen will appear.
9. On the Service screen, use up and down arrows [1R] and [3R] to select the Small Pump Calibration Factor.
10. Use the keys corresponding to the up and down arrows [1R] and [3R] to enter the new calibration factor. Press the Enter button [2R].



**Tip:** For greatest accuracy use all three decimal places.

Example:

Starting tank volume = 425 gallons

Ending tank volume = 50 gallons

Measured volume = 375 gallons

Job total = 378 gallons

Old calibration factor = 1000

$$\frac{(425 - 50) (1000)}{378} = 992$$

## Storage

Before and after a storage period of 6 months or longer, perform the following procedure:

1. Follow the tank and pump clean out procedures if emulsion remains in the spray paving system. If the spray paving system is already cleaned out proceed to step 2.
2. Fill the emulsion tank with approximately 20 gallons (76L) of diesel fuel. This should be enough to fill the sump of the tank and submerge the floor of the tank.
3. Run the **Tank Circulate** pump function. Adjust the pump flow rate to 100%.
4. Remove one of the emulsion tank covers, and look into the emulsion tank to see if diesel fuel is circulating in the tank. Add diesel fuel to the tank if the suction line for the pump is not submerged and sucking air.
5. Continue running **Tank Circulate** for 10 to 15 minutes.
6. Run the **Spray Bar Circulate**. Adjust the pump flow rate to 100%.
7. Continue running **Spray Bar Circulate** for 10 to 15 minutes, and then turn the pump off.
8. Run the spray bar vacuum procedure (page 96).
9. Turn off the pump.
10. Remove the diesel fuel from the emulsion tank before adding hot emulsion to the tank.

# Startup after storage

## Hydraulics system check

1. Before starting the paver, check the spray paving system hydraulic reservoir fluid level and perform a visual inspection of all hydraulic components.
2. Power on the spray paver display screen unit using the power button on the pendant, and start the paver's engine.
3. Verify the right and left telescoping spray bars extend and retract and the front spray bar tilt functions.



**Note:** Retract the locking pin on the front spray bar to tilt. In some models this must be done manually.

## Cleaning agent check

If the machine was properly stored, there will be cleaning agent (typically diesel fuel) inside all spray bar pipes and in the emulsion tank(s).

To ensure Tank Circulate and Spray Bar Circulate can be run without pulling air on the suction side, unbolt and remove an emulsion tank cover, and look into the tank to be certain that the tank suction (outlet) port is submerged with release agent.

- If the spray bars contain cleaning agent, but the level in the emulsion tank is not high enough to cover the suction port, directly add cleaning agent to the tank.
- If there is no cleaning agent inside the spray bars, run the Clean Out pump functions to circulate cleaning agent through the spray bars and back into the emulsion tank.



**Note:** Open the manual ball valve at the cleaning agent tank when running the Clean Out functions, and then close the ball valve when complete.

## Function check

Verify proper operation of each spray paver function.

### Tank Load

1. Activate the **Tank Load** pump function to verify operation.

 **Note:** If the cleaning agent within the tank is above the suction (outlet) port, the emulsion tank will not need to be loaded at this time.

2. Verify both the small and large asphalt pumps shafts are rotating. The small pump flow rate is fixed at a low speed, but the large pump speed can be adjusted using the up and down arrows.
3. Verify valve actuator (open & closed) positions using the diagram in Appendix 2: Pump group flow paths (page 136).

### Tank Circulate

1. Activate the **Tank Circulate** pump function to circulate cleaning agent from the emulsion tank to the asphalt pumping station and then back to the emulsion tank. Circulate for a minimum of 5 minutes at a high flow rate.
2. Verify both the large and small asphalt pump shafts are rotating. The small pump flow rate is fixed at a low speed, but the large pump speed can be adjusted using the up and down arrows.
3. Verify valve actuator (open & closed) positions using the diagram in Appendix 2: Pump group flow paths (page 136).

### **Spray Bar Circulate**

1. Activate the **Spray Bar Circulate** pump function to circulate cleaning agent from the emulsion tank to the asphalt pumping station, through all the spray bars and back to the emulsion tank.
2. Verify both the small and large asphalt pump shafts are rotating. The large pump flow rate is fixed at a low speed, but the small pump speed can be adjusted using the up and down arrows. Circulate for a minimum of 15 minutes at a high flow rate.
3. Verify valve actuator (open & closed) positions using the diagram in Appendix 2: Pump group flow paths (page 138).

### **Spray Auto**

1. Install clean spray nozzles of the appropriate nozzle opening for the application rate and paving speed of the job.
2. Activate the **Spray Auto** pump function and verify proper operation. The spray nozzles will not spray until the master spray switch on the pendant is turned on.
  - If the master spray switch is off and the Spray Auto pump function is active, the small asphalt pump will run at a constant flow rate of 5 gpm.
  - With the master spray switch on, the small asphalt pump speed is regulated to supply the application rate based on the vehicle speed and the selected spray width. If the vehicle is not moving, the flow rate from the asphalt pump will be reduced to zero.
3. Verify valve actuator (open & closed) positions using the diagram in Appendix 2: Pump group flow paths (page 136).
4. Verify all spray nozzle actuators function properly (observe them open and close), by turning them on and off with the navigation arrow and the OK button on the Sprayer Selection screen.

### **Spray Bar Vacuum**

1. With the paver engine running at high idle (full speed), activate the Spray Bar Vacuum pump function. Verify both the large and small asphalt pump shafts are rotating.
2. Verify valve actuator (open & closed) positions using the diagram in Appendix 2: Pump group flow paths (page 140).

### **Clean Out**

1. Activate the Clean Out function. Verify the small and large asphalt pump shafts are rotating.
2. Verify valve actuator (open & closed) positions using the diagram in Appendix 2: Pump group flow paths (page 141).



# Troubleshooting

Problem	Root Cause	Solution
Resin in the emulsion tank hardened.	Tank not properly emptied after use	Clean the emulsion tank (see page 125).
Blocked nozzles or nozzles spraying unevenly across spray bars	Spray bar cold due to poor circulation of hot emulsion through the spray bars, which is in turn caused by blockage or incorrect valve alignment	Make sure emulsion in the tank is 180° F or hotter. 1. Run Tank Circulate to heat the plumbing in the pump station. 2. Run Spray bar Circulate. If the spray bar begins to warm slowly, continue to run Spray bar Circulate for 10 minutes to melt any hard emulsion in the spray bar. If hot emulsion is not flowing through the spray bar, check alignment of the pump station valves (see Appendix 1).
	Nozzles mismatched	Verify all nozzles are the same size and style.
	Flow rate for nozzles too low	Increase flow through nozzles by 1, increasing application rate and/or 2, increasing travel speed. If 1 and 2 cannot be done or do not resolve the problem, install lower capacity nozzles.
Nozzle's spray stopping sporadically	Clogged nozzle	Remove the nozzle, and rinse it with clean out fluid to flush out any solid particles and dissolve hardened emulsion.
Spray nozzles continue to drip although closed	With center or inner spray bar nozzles: Spring tension too low	Clean emulsion from the top of the valve to free spring. If still too loose, add washers to increase tension.
	With outer spray bar nozzles: locknut too loose	Tighten the locknut on valve stem.
Emulsion pump stuck	System not cleaned after use	Clean the pump (see page 129).
Emulsion small pump bypass occurring under normal pressure (spray pressure too low)	New pump installed	Set the small pump bypass setting (see page 132).
	Adjustment screw inadvertently reset	

<b>Problem</b>	<b>Root Cause</b>	<b>Solution</b>
<b>No suction from clean out tank</b>	<b>Blockage in lines</b>	<b>Make sure the hose and fittings from the clean out tank to pump station are clear of blockage.</b>
	<b>Pump lost prime</b>	<b>1. Remove lid of strainer basket. 2. Put pumps in Vacuum mode. 3. Pour clean out fluid into the strainer basket. Stop pumps at the same time as you stop pouring clean out fluid into the basket. 4. Replace the lid. Pumps should now be primed.</b>
	<b>Pump station valves misaligned</b>	<b>Check valve alignment. (see Appendix 1)</b>
<b>Pump speed incorrect</b>	<b>Feedback signal lost to controller (If this is the case, the display will read pump speed of 0 rpm even when the pump is turning), likely due to loose or broken wires.</b>	<b>Check connection of speed sensor wire on hydraulic motors in the pump station. Check the wire connection on the outside of the pump station and at the control box.</b>
	<b>Incorrect calibration factor</b>	<b>Perform pump calibration procedure (see page 100).</b>
<b>Spray, pump, or tank valves not actuating</b>	<b>Spray valves temporarily stuck</b>	<b>Try to physically move the valve to assist air pressure. At soon as possible, flush the system with lubricating clean out fluid (such as diesel fuel). Push down on the spray valve stem to flush fluid through inside of valve. Clean the exterior of the valve, and coat it with light weight oil to prevent corrosion.</b>
	<b>Electric/pneumatic valve not actuating due to faulty wiring</b>	<b>If the valve does not move when actuated from the controller, use the manual override on the pneumatic valve. If this moves the valve, the electric solenoid is not working. Look for and fix loose or broken wires in the air box. The solenoid should get 24 V when it is “on” at the controller. It should have no voltage when “off.”</b>

<b>Problem</b>	<b>Root Cause</b>	<b>Solution</b>
	Electric/pneumatic valve not actuating due to internal stickiness, which is likely caused by water and rust in the compressed air system	<ol style="list-style-type: none"> <li>1. Shut off compressed air.</li> <li>2. Remove the pneumatic/electric valve from manifold in box.</li> <li>3. Disassemble the valve, and clean and lubricate the internal mechanism. Alternatively, or if corrosion is significant, replace the electric/pneumatic valve (part IDX20780).</li> </ol>
<b>Air pressure low</b>	Valve shut off	Turn on the ball valve at the output of the compressor unit.
	Regulator set too low	Adjust the regulator to increase pressure. (Note: system pressure cannot be set higher than tank pressure)
	Compressor cannot keep up with air use	Do not actuate any valves for 1 minute or until compressor shuts off.
	Excessive air leaking in the system	<ol style="list-style-type: none"> <li>1. Park the spray paver in a quiet location.</li> <li>2. With air system pressurized, shut off the engine, and listen for leaking air.</li> <li>3. Where leaks are found, tighten threaded fittings, push in tubes, and replace failed O-rings.</li> <li>3. Use manual override to switch all air valves to their alternate position.</li> <li>4. Re-pressurize the system.</li> <li>5. Shut off the engine and listen again.</li> </ol>
	Filter element full (if equipped with three-stage air filter)	Replace the filter element with IDX20291.
<b>Heating elements not turning on</b>	No power to heater box	Turn on the paver accessory power, or plug into a shore power outlet.
	Low emulsion in tanks	Heater should not operate when emulsion level in tanks is below heat elements. This is normal.
	GFCI (Ground Fault Circuit Interrupter) tripped	Open the heater box, and push "reset" button on GFCI box
	Thermostat set too low	Open the heater box. Turn up the thermostat until heater relays engage. Warning: Do not leave the thermostat setting above 200° F.

<b>Problem</b>	<b>Root Cause</b>	<b>Solution</b>
	<b>Over temperature switch activated</b>	The switch is located at the front of the tank. If adjustable, make sure it is set at 200° F. If the emulsion in the tank reaches 200° F or higher, the heaters are disabled until the temperature is reduced.
<b>Display screen unit doesn't turn on</b>	<b>No power to display</b>	Check for secure connection of the power cable at the rear of the display screen unit. Make sure the controller is powered on (if not see below).
<b>Controller doesn't turn on or shuts down inadvertently (a green light on the side of the controller, located inside the main control box, indicates power)</b>	<b>Loss of main power to Spray Paver system</b>	Make sure the battery disconnect switch of the paver is turned on.
	<b>Pendant not plugged in securely</b>	Plug the pendant securely to the control box.
	<b>Lost contact in power wire connections in the pendant</b>	Open the pendant enclosure, and make sure all wires are securely screwed to switch terminals.
<b>Overflowing hydraulic tank</b>	<b>Hydraulic tank overfilled</b>	Drain oil from hydraulic tank to reduce oil level. When the oil is cool, the level should be no higher than ½ of the way up the sight glass.
<b>Telescoping spray bars do not function</b>	<b>Obstruction</b>	Check hydraulic cylinders and telescoping spray bars for physical blockage or damage.
	<b>Hydraulic valve not actuating</b>	Check wire connections to the manifold valve block in pump station. One pair of wires should have 24 V when function is activated at display.
<b>Tilt function not working</b>	<b>Tilt lock pins engaged</b>	The lock pins should automatically disengage when activating tilt. This indicates a different problem. Contact the factory.
	<b>Obstruction</b>	Examine area around front spray bar and tilt cylinder (under, behind right side of spray bar) for physical blockage. Remove blockage.
	<b>Faulty cylinder</b>	Use a lift or jack to manually tilt up the spray bar. Then use controller to actuate cylinder and see if it functions properly.

**Table 12:** Troubleshooting

## Cleaning the emulsion tank



**Avoid damage:** Do not run the Spray Bar Circulate with solid or gel material in the emulsion tank. Running Spray Bar Circulate with solid emulsion in the emulsion tank may plug the spray bar hoses and also introduce large particles into the spray bars



**Warning:** The tank may contain dangerous fumes that can cause injury or death. Do not enter or allow anyone else to enter the tank.

Severe clogging will occur if the tank was left without release agent and not properly cleaned after prior use. Clean it out as follows:

1. Using a long-handle hoe or straight scrapers, scrape and remove as much hardened material as possible from the tank bottom areas.



**Avoid damage:** Be careful not to damage heat elements. Also be careful not to damage the tank level float and tank high temperature switch.

2. Fill the tank to a least 75% full with fresh (not reheated many times) emulsion at 195° F (90° C). (Fresh emulsion carries the optimum water amount and is less susceptible to hardening.)
3. Immediately run the tank circulate pump function for 20 to 30 minutes with the tank heating system on.
4. Make sure the pump flow rate at the top of the Pump Function Screen on the display is at 100% while the tank is circulating.

5. Look inside the emulsion tank to verify that emulsion is circulating.
6. During circulation, maintain emulsion temperature close to 195° F (90° C), so it does not cool below 165° F (75° C) before the tank circulation is complete. (If it drops below 165° F (75° C), the old emulsion may not melt.)



**Tip:** To increase tank heat, place the covers on top of the tank, and turn on the tank heating system.

7. After 20 to 30 minutes, check inside the tank to see if the old emulsion has melted away.
8. If the old emulsion has melted away, proceed to step 10.
9. If the old emulsion has not melted away, continue circulating for another 30 minutes before proceeding to step 10. You may need to pump out and replace emulsion if the emulsion temperature falls below 165° F (75° C).
10. Vacuum out the emulsion in the tank back into bulk holding (distributor truck).
11. Immediately fill the tank with 20 gallons (76 L) of release agent (or enough to cover the bottom of the tank at a depth of 1 to 2 inches), and run the tank circulate pump function for 15 minutes.

12. Look in the tank to verify the release agent is circulating. Add more release agent if necessary to prevent the suction line from the pump from drawing air.
13. Inspect to see if the hardened emulsion is gone.
14. If the tank appears clean, proceed to the next step.
15. If hardened emulsion remains, repeat steps 1 through 7.
16. Remove the spray bar nozzles. If they were not cleaned properly, clean their orifices. Do not put them back in.
17. Fill the tank with emulsion at 185° F (85° C). Run **Tank Circulate** for 10 minutes. After running tank circulate, run **Spray Bar Circulate** for 10 minutes. During circulation, keep the emulsion temperature above 165° F (75° C).
18. While driving and with the application rate set at 2.0 gal/yd<sup>2</sup>, spray some emulsion out a 2 to 3-ft section of the spray bar at a time. Repeat until entire width has been flushed with hot emulsion.



**Note:** Trying to spray out of too many valves at same time, with no nozzles inserted will only allow flow from a few (because no pressure will build inside the spray bars).

19. After spraying is complete, immediately run **Spray Bar Circulate**.
20. Spin the nozzles into the left four-foot telescoping spray bar. Align the nozzles as shown in Figure 9. Tighten the nozzles slightly with a wrench. Do not over tighten.

21. Spray out of the left four-foot telescoping spray bar only to check clogging. Some nozzles may need to be re-cleaned as debris is worked out. When the nozzles are spraying properly, add more sections of nozzles.

22. Run **Spray Bar Circulate**. Load emulsion.

23. Spray over a short stretch. If flow is occurring through a partially-clogged nozzle, allow it to spray for a short time to see if hot emulsion melts away the clog. Otherwise clean the nozzle.

 **Note:** Since the spray paver has overlap, a few clogged nozzles will not critically affect spray coverage.

24. When you are finished, run **Spray Bar Vacuum**, and vacuum each spray bar section starting with the center, and then continuing with the left and right telescoping spray bars and finishing with the rear spray bars, and suck emulsion tank empty back to bulk holding.

25. Make sure the clean out tank is full of release agent.

26. Run **Spray Bar Clean Out**, and run the pump for about 1 minute.

27. Verify the release agent level in the clean out tank has dropped due to running the pump clean out function. The pumps and spray bars are now flushed with diesel fuel.

28. Add about 20 gallons (76 liters) of release agent to the emulsion tank, and run **Tank Circulate** at a rate of 100% for 5 minutes while verifying the entire bottom of the tank remains submerged in release agent. Add additional release agent if necessary.



## Cleaning a stuck pump



**Warning:** Be sure to power off the spray paving system and the hydraulic pump for the spray paving system before removing hardened emulsion from the emulsion pumps.



**Danger:** Do not place tools or hands in the rotating components of the emulsion pumps.

If an emulsion pump driveshaft does not turn when the hydraulic pump is on and a pump function is active (highlighted in green on the Pump Function screen), the emulsion pump has likely clogged with emulsion and seized. Clean as follows:

1. Remove the pumping station cover.
2. Remove the strainer housing cover (see Figure 56).

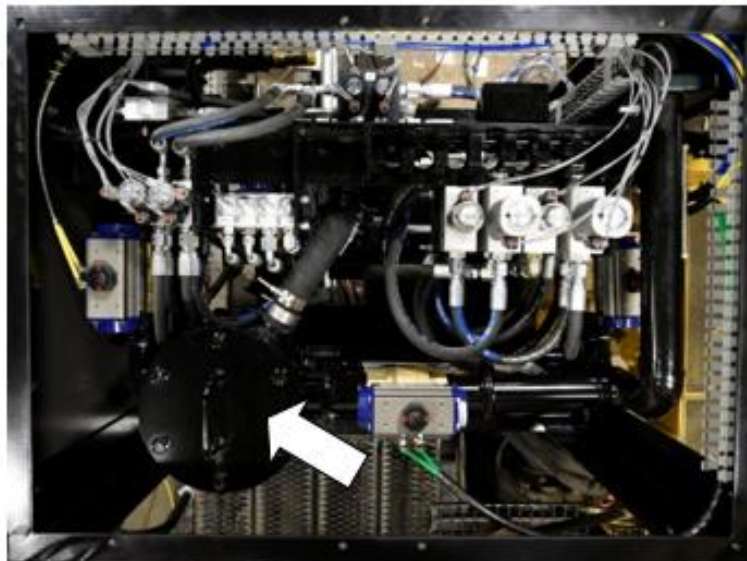

**Figure 56:** Strainer housing, top view

3. Remove all hardened emulsion from the strainer housing
4. Fill the strainer housing with release agent (or a solvent that will break down emulsion).
5. Be sure all systems are powered off, and rotate the pump shaft of the clogged pump using a pipe wrench. If the shaft cannot be turned with a pipe wrench, the solvent may need some time to soak into the hardened emulsion. Turn the shaft clockwise and counterclockwise to work the solvent into the pump.
6. If both emulsion pump shafts can be turned, run **Spray Bar Vacuum** (Figure 57) at maximum pump speed. This pump function will suck the solvent from the strainer housing into the emulsion tank.

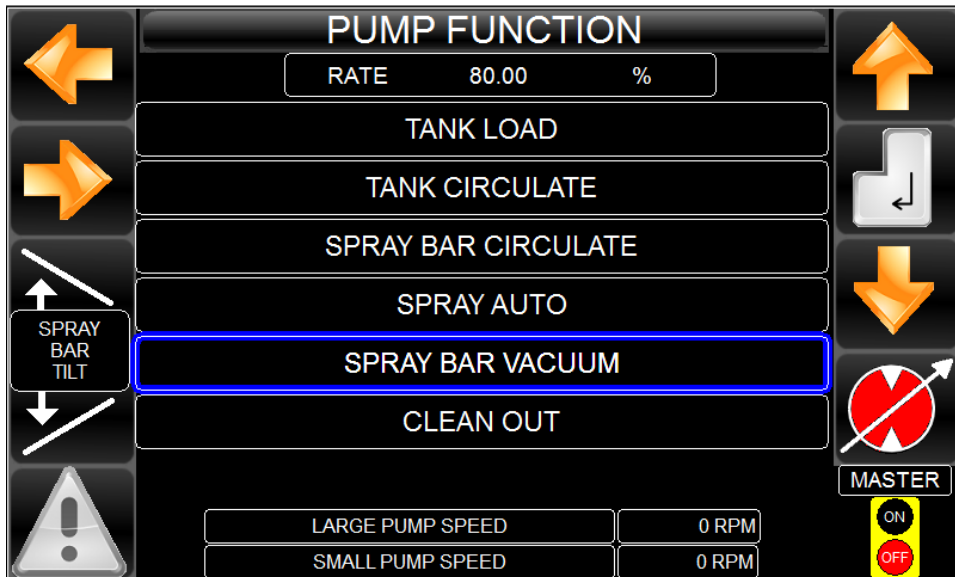

Figure 57: Spray bar vacuum

7. Once the solvent has been sucked into the emulsion tank, the emulsion pumps will be running in reverse and sucking air into the emulsion tank. Additional solvent may be poured into the strainer housing if desired.
8. Alternate between the spray bar vacuum pump function (pump reverse) and the tank circulate function (pump forward) to flow material through the pumps in both directions.
9. Reinstall the strainer housing cover.
10. If the solvent and pipe wrench do not free the driveshaft after several hours of soaking, then a torch may be used to melt down hardened asphalt as a last resort.



**Warning:** If a torch is used be sure to remove any flammable solvents from the area to prevent fires or explosions. An infrared temperature gun is required to be sure that the pump is not heated above 212° F (100° C). If the asphalt emulsion boils it may explode and cause bodily injury.

## Setting the small emulsion pump bypass pressure

The emulsion pump bypass pressure is set at the factory and normally will not need to be adjusted. However, if the bypass pressure is set so emulsion bypasses within the pump at too low of a pressure, the flow rate will not be accurate. This is a problem with the small emulsion pump, which requires accurate flow for accurate control of the application rate.

Check and reset the small emulsion pump bypass pressure as follows:

1. With the paver shut off, remove the screw cap that covers the adjustment screw on the small emulsion pump relief valve.
2. Loosen the lock nut on the adjustment screw.
3. Turn the bypass adjustment screw all the way clockwise.
4. Tighten the lock nut.
5. Reinstall the adjustment screw cap.

## Appendices

1. Valve and emulsion pump configurations for each pump function
2. Firmware update instructions
3. Maintenance record
4. Emulsion tank configuration

## Appendix 1: Valve and emulsion pump configurations for the pump functions

Pump function	Tank outlet valve 2.0"	Tank return valve 2.0"	Spray bar #1 valve 1.5"	Spray bar #2 valve 1.5"	Large pump isolation valve #2 (tank outlet side) 2.0"	Spray bar isolation valve #1 (tank return side) 2.0"	Small pump (Fwd/Rev 1 gpm increments)	Large pump (FWD/REV 5 gpm increments)
Tank load	Closed	Open	Closed	Closed	Open	Open	FWD 5 gpm	FWD 10-50 gpm
Tank circulate	Open	Open	Closed	Closed	Open	Open	FWD 5 gpm	FWD 10-50 gpm
Spray bar circulate	Open	Open	Open	Open	Open	Closed	FWD 1-10 gpm	FWD 5 gpm
Spray auto	Open	Closed	Open	Open	Closed	Open	FWD variable	Off
Spray bar vacuum (fixed pump rates @ 80% flow each)								
Spray bars	Open	Closed	Open	Open	Open	Open	Rev 16 gpm	Rev 40 gpm
Clean out	Closed	Open	Open	Open	Open	Closed	Fwd 5-18 gpm	Fwd 12 gpm
Off	Closed	Closed	Closed	Closed	Closed	Closed	Off	Off

See next page for valve location

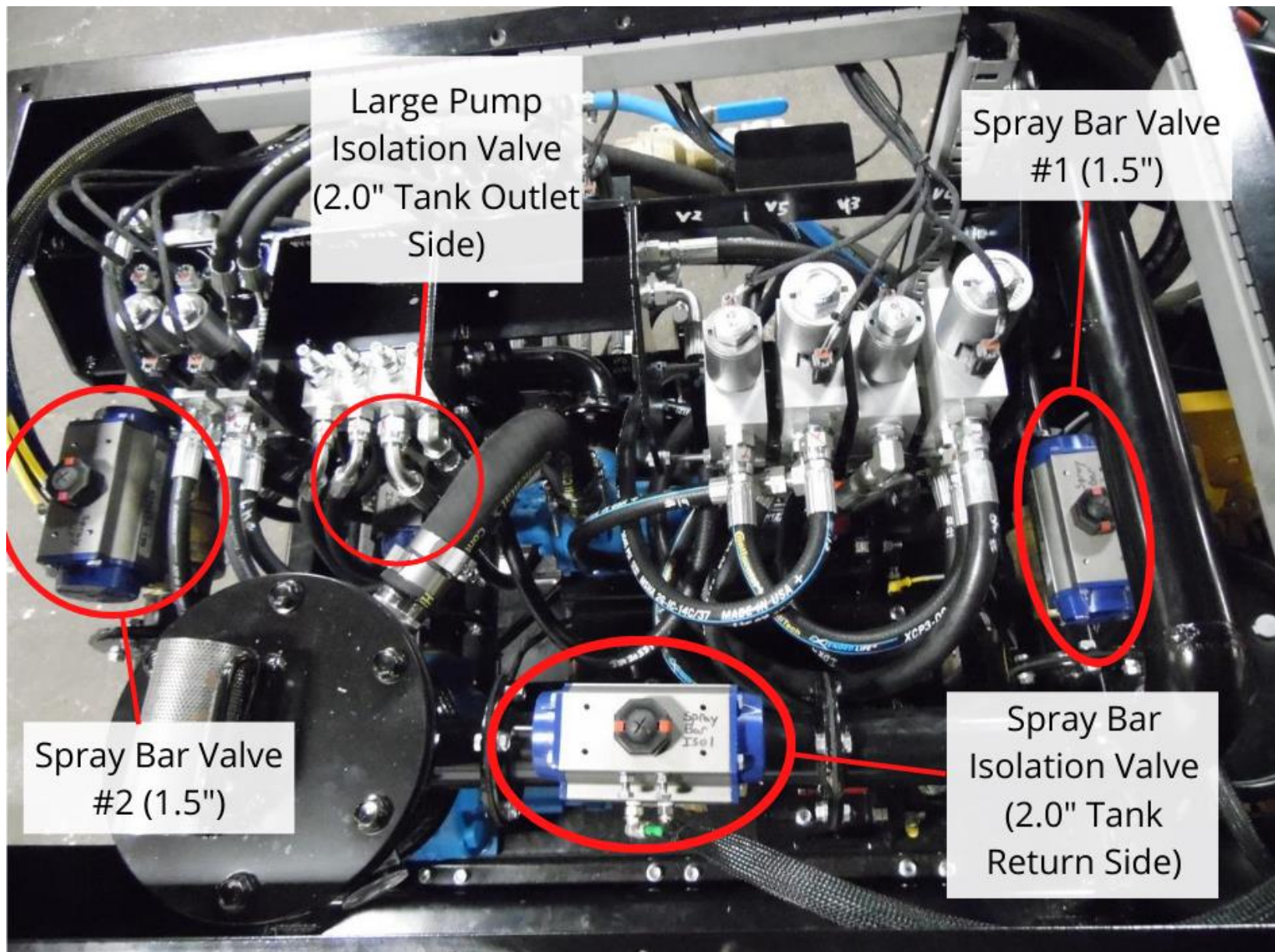

# Appendix 2: Pump group flow paths

## Tank Load

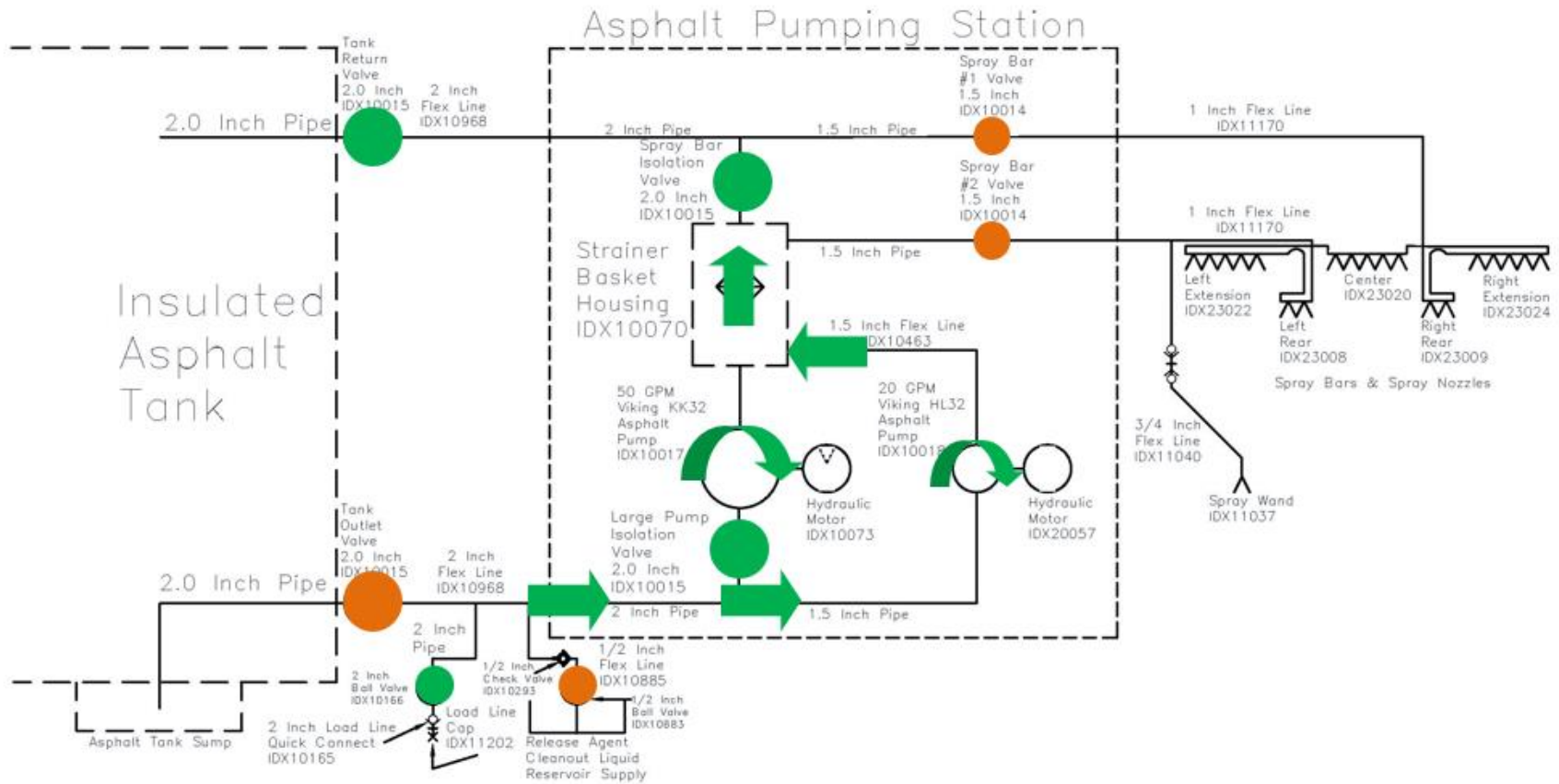



# Tank Circulate

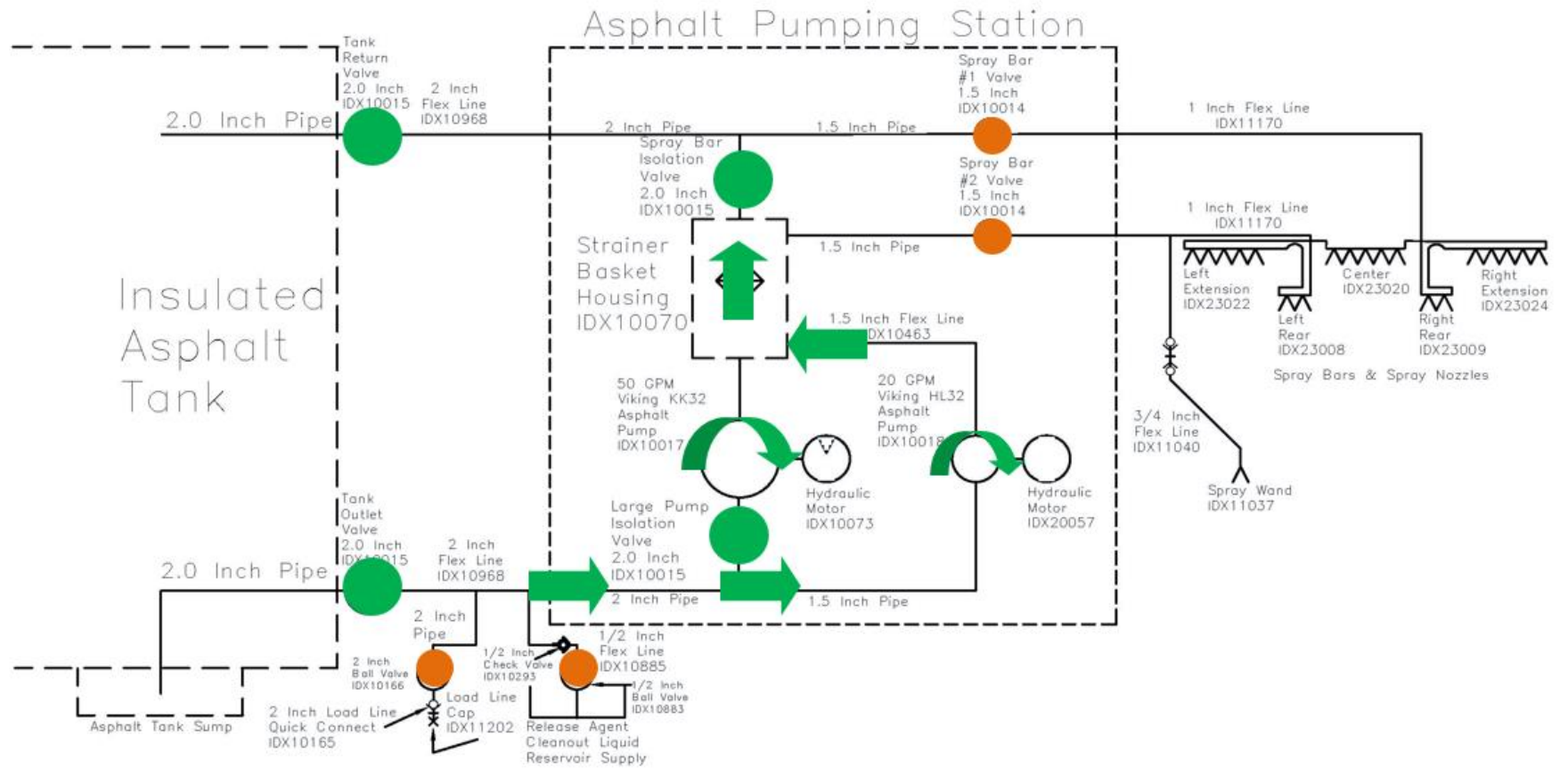

# Spray Bar Circulate

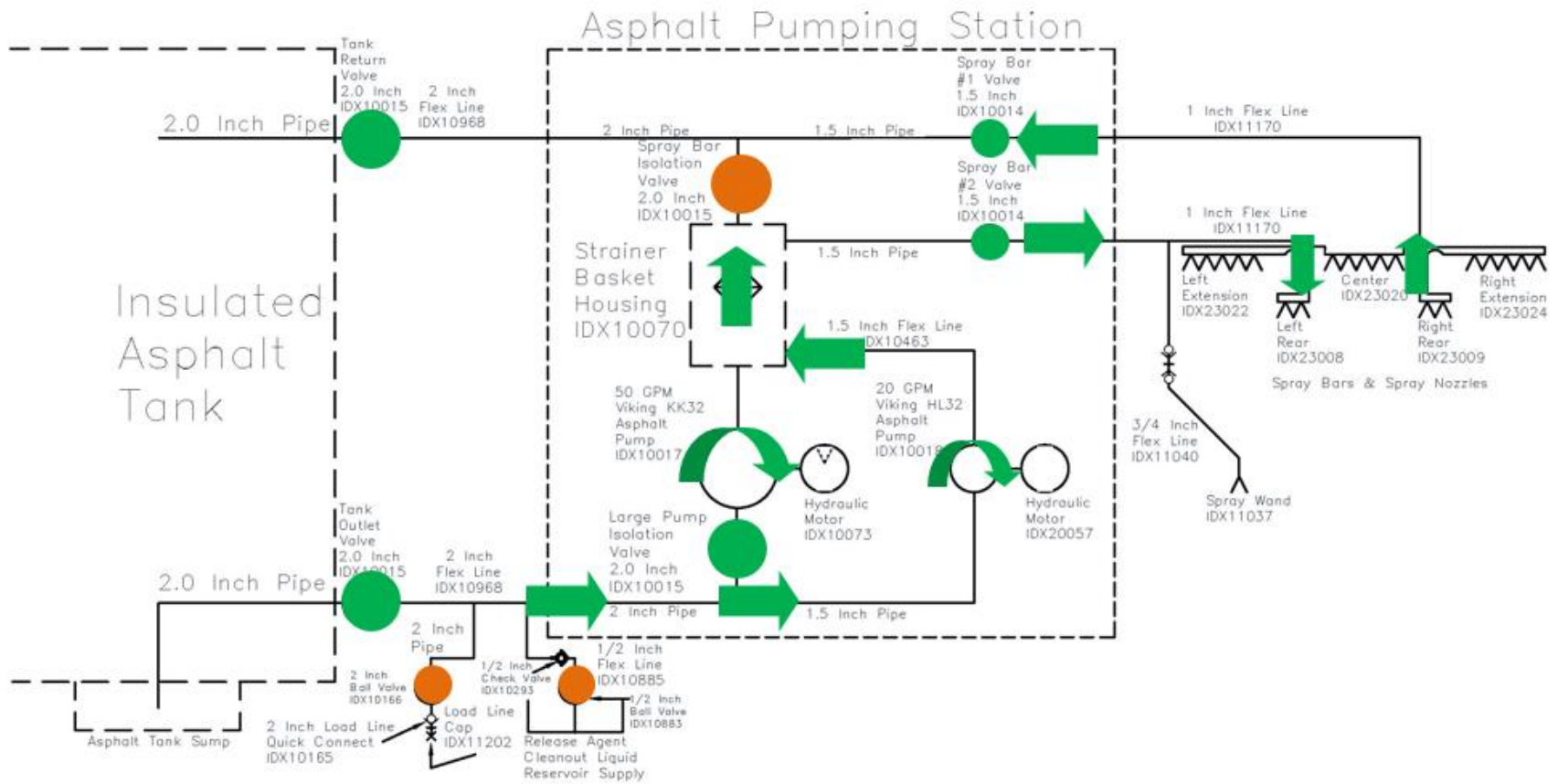

# Spray Auto

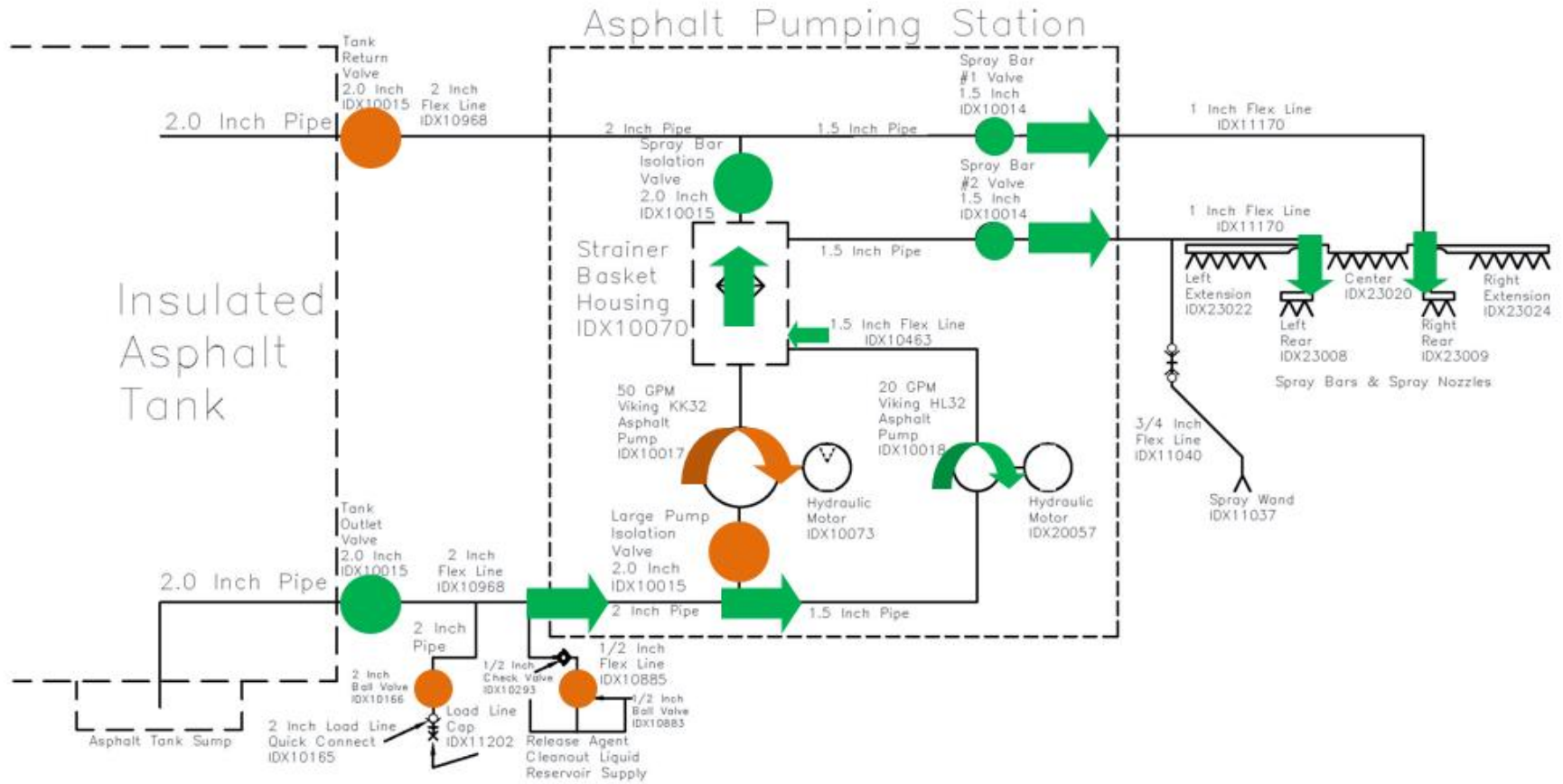

# Spray Bar Vacuum

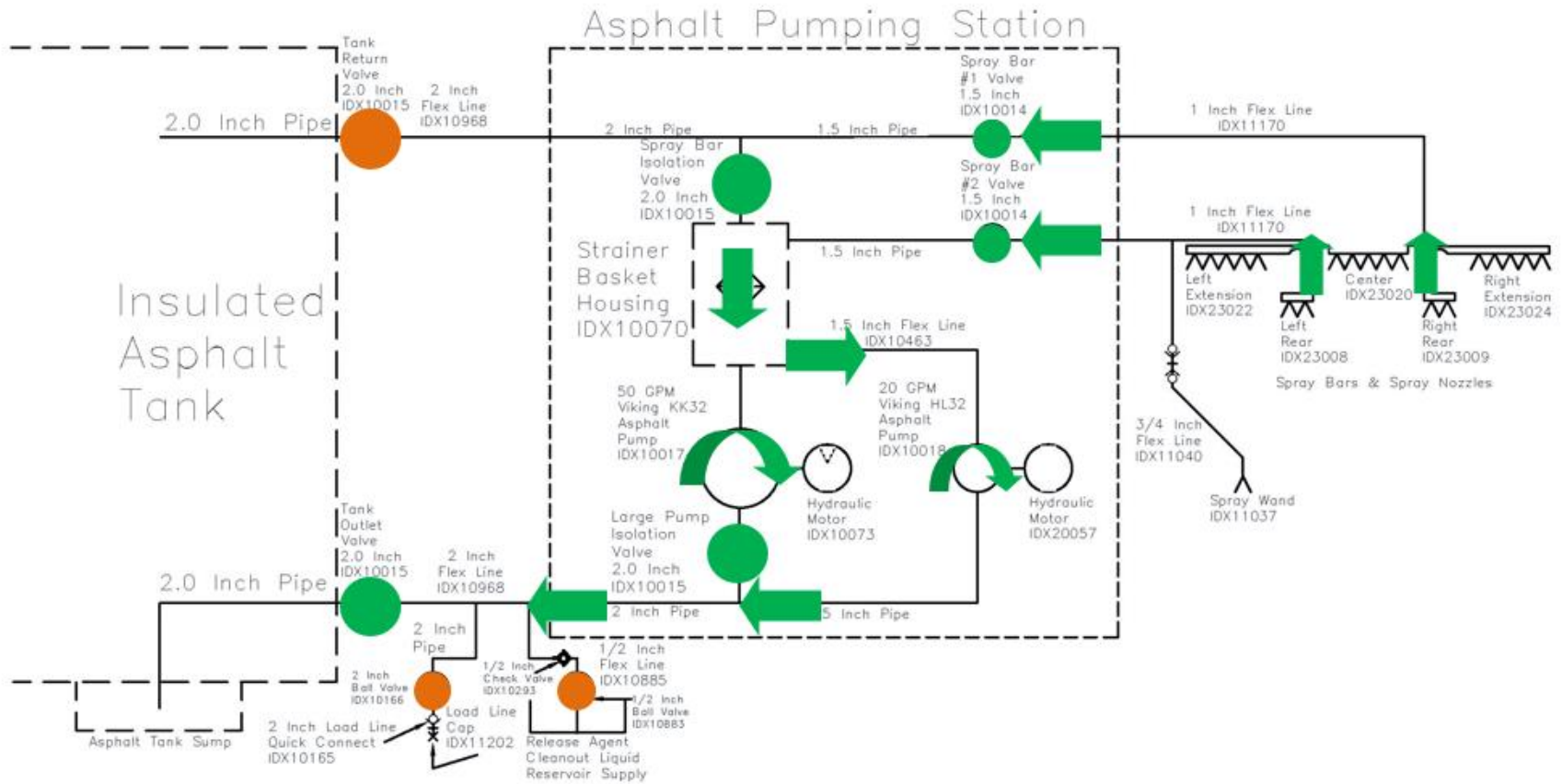

# Clean Out

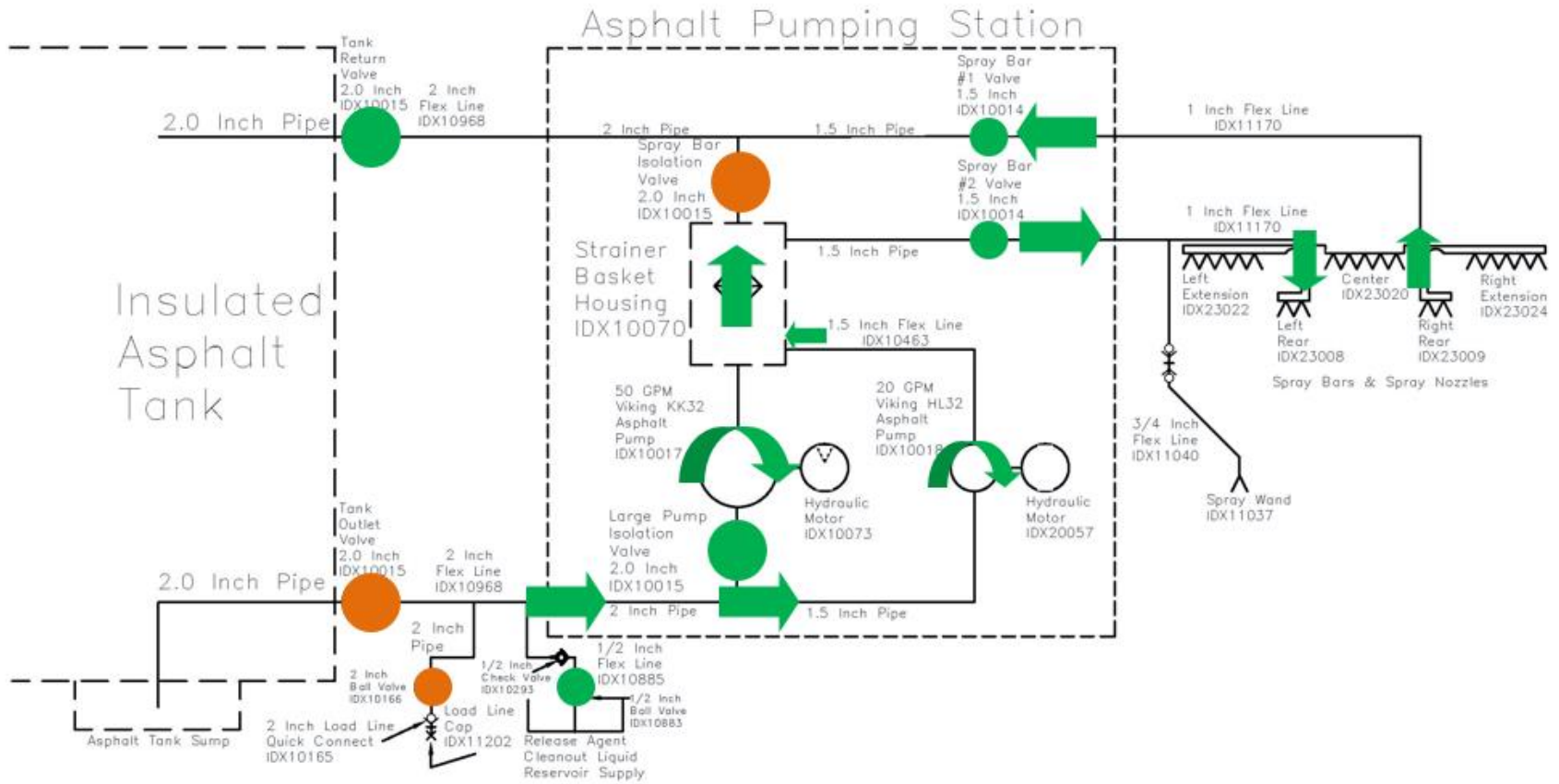

## Bypass Setting

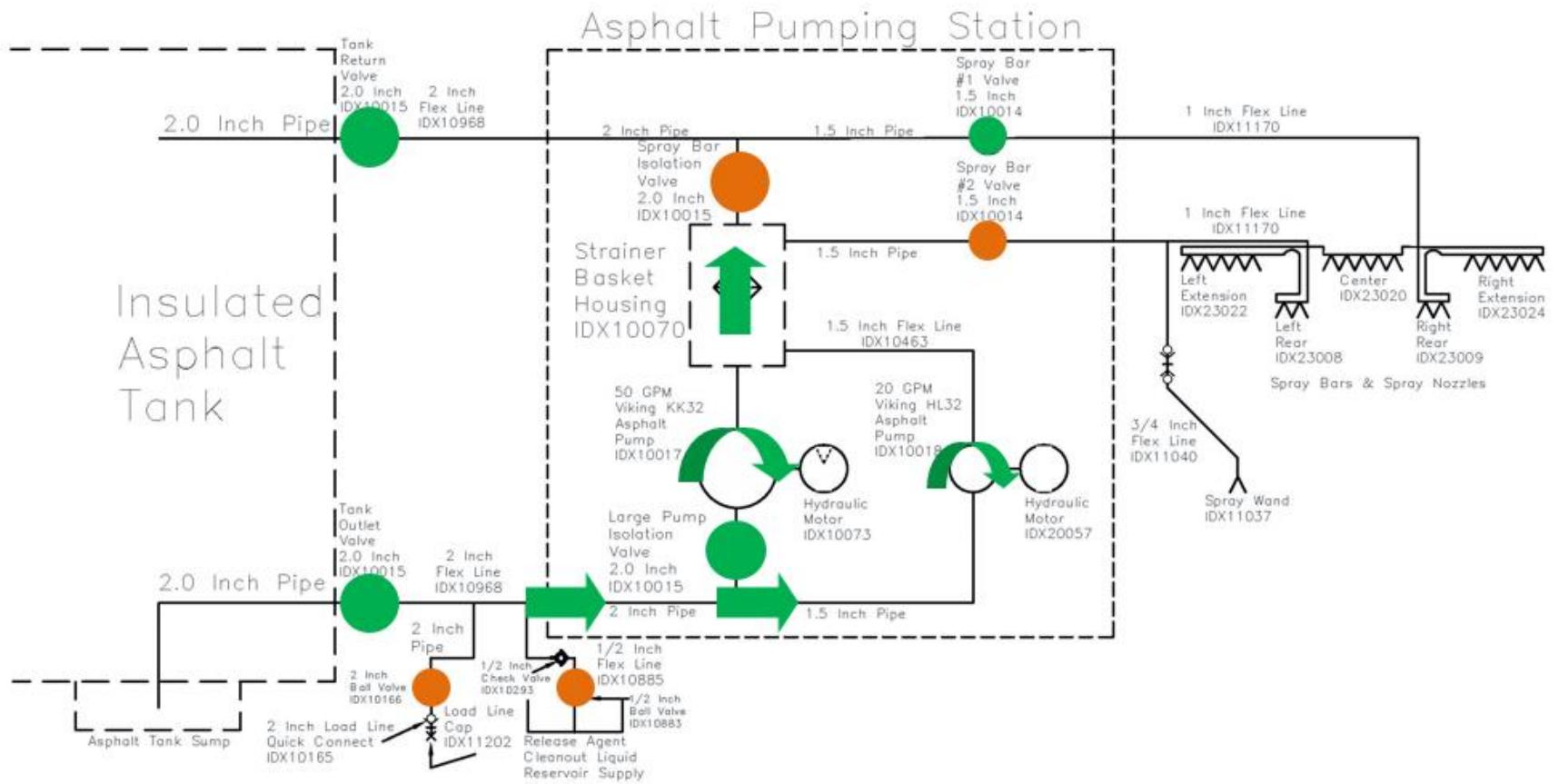

**Note:** These settings must be done manually.

## Appendix 2: Updating PLC and display software

### Downloading and running the software

1. Create a new folder on the desktop of a laptop computer.
2. Download the three zipped software installation files to the new folder.
  - CODESYS\_V23942\_V35
  - download\_V061710
  - Maintenance 2.5.3.227020.140
3. Right click the zip file “CODESYS\_V23942\_V35.” From the menu, select **Extract All**. Browse to the new folder, and click **Extract**. In the extracted file, double click on the “**Setup**” file.
4. Right click on the zip file “download\_V061710.” From the menu, select **Extract All**. Browse to the new folder, and click **Extract**. In the extracted file, double click on the windows installer package file “**DOWNLOAD\_v061827**.” Select **Run**.

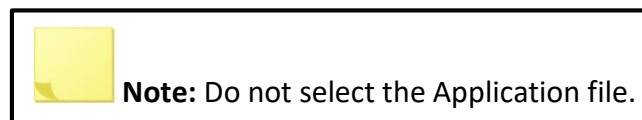

5. Right click on the zip file “Maintenance 2.5.3.227020.140.” From the menu, select **Extract All**. Browse to the new folder, and click **Extract**. In the extracted file, double click on the “**Setup\_Release\_2.5.3.227020.140**” file.

## Programming the display screen unit

1. Using Ethernet cable 1DX10880 (Figure 58), connect the Ethernet port on the computer to the Ethernet programming connection on the back of the display screen unit (see Figure 59).



**Figure 58:** Ethernet cable 1DX10880



**Figure 59:** Displays screen unit back side showing the Ethernet cable connection

2. Turn on the display screen unit.



3. The IP address on the computer may need to be manually configured as follows:
  - a. Go to **Control Panel>Network and Sharing Center**.
  - b. Under “**View your active networks,**” click **Local Area Connection**.
  - c. Click **Properties**.
  - d. On the **Network** tab, select Internet Protocol Version 4 (TCP/Pv4), and click **Properties**.
  - e. Select “Use the following IP address,” and enter 192.168.082.200.
  - f. Click **OK**.
4. Open the CoDeSys software, either from the start menu or the software file.
5. Verify the communication parameters are set up correctly within CoDeSys:
6. From the menu bar, select **Online>Communications Parameters**.
7. For each channel under ‘localhost’ via Tcp/Ip, select the channel, and then click **Remove**.
8. Click **Update**.
9. Wait for the status indicator to stop, and then click **Update** again. The new IP address will appear. It should be **192.168.82.247**.
10. Click **OK**.
11. From the CoDeSys program menu bar, select **Online>Login**, and click **Yes**.



**Note:** If a dialogue box says there is a communication error, click OK, and try the following fixes in order until the problem is resolved:

- Check to see if the green LED inside the laptop Ethernet port is on. If it is not on, restart the laptop.
- Re-verify the communication parameters are setup correctly (step 5).
- Close and restart the CoDeSys software.

12. Check to see if the green LED inside the laptop Ethernet port is on. If it is not on, restart the laptop.

13. Re-verify the communication parameters are setup correctly (see step 5).

14. Close and restart the CoDeSys software.

15. From the menu bar, select **Online>Run** to turn on the display software.

16. From the menu bar, select **Online>Create boot project**.

 **Note:** You will not be able to select Run after creating a boot project as the software is already running.

17. From the menu bar, select **Online>Logout**. If you are asked to save changes, select **No**.

18. Disconnect the computer from the display screen unit.

 **Note:** After installing the CoDeSys software, return the computer Network and Sharing Center to the original settings.

## Programming the control unit

1. Using a IDX10800 programming cable (Figure 60), connect the computer to the control unit programming cable.



**Note:** If your computer does not have a modem port, connect the programming cable to a USB-to-serial converter (e.g., a TRENDnet TU-S9 as shown in **Figure 61**).



**Figure 60:** 1DX10800 programming cable



**Figure 61:** USB-to-serial adapter IDX20229

2. Turn on the control unit.
3. Select **Control Panel>Device Manager**. From the list, expand the **“Ports”** icon to identify the COM port used by the USB cable that is connected to the PLC.



**Tip:** Disconnecting and then reconnecting the programming cable will identify the port by making the list item disappear and reappear.

4. Select the COM port within the CoDeSys communication parameters:
5. From the menu bar, select **Online>Communications Parameters**.
6. For each channel under ‘localhost’ via Tcp/Ip, select the channel and then click **Remove**.
7. Click **Update**.
8. Wait for the status indicator to stop, and then click **Update** again.
9. Double click on **Value**.
10. Uses the up and down arrows on the keyboard to adjust the port value until it matches the COM port determined in step 3.

11. From the CoDeSys program menu bar, select **Online>Login**.



**Note:** If a dialogue box says there is a communication error, click **OK**, and try the following fixes in order until the problem is resolved:

- Re-verify the communication parameters are setup correctly (step 5).
- Close and restart the CoDeSys software.
- Restart the laptop

12. In the dialog box that asks if you want to download a new program, click **Yes**.

13. From the menu bar, select **Online>Run**.

14. From the menu bar, select **Online>Create boot project**.

15. From the menu bar, select **Online>Run**.

16. From the menu bar, select **Online>Logout**. If you are asked to save changes, select **No**.

17. Disconnect the computer from the control unit.

## Appendix 3: Maintenance record

Task	Hours	Serviced by	Hours	Serviced by
<b>As required</b>				
Clean the spray wand.				
Clean the machine.				
Clean the strainer screen in the pumping station.				
<b>Daily</b>				
Check the hydraulic oil level.				
Inspect hydraulic hoses and emulsion hoses.				
Check the fluid level in the clean out tank.				
Clean blockage from the emulsion tank overflow tube.				
Clean the hydraulic cylinder rods.				
Drain the air compressor tank and air filter.				
Open and drain tank sump.				
<b>Weekly</b>				
Inspect the packing gland on the emulsion pumps.				
Inspect the emulsion pump coupler.				
Lubricate the emulsion pump bearings				
Inspect the packing gland on the emulsion tank.				
Check the tightness of the tank tie-down hardware.				
Check the spray bar hardware.				
Check the condition of the hydraulic filter.				
Check oil level in the compressed air oiler				
<b>Annually or after every 400 hours</b>				
Change the hydraulic oil and filter.				
Change the fluid in the clean out and fuel tank.				
Replace engine air filter element.				

**Table 13:** Service record

## Appendix 4: Emulsion tank configuration

Distance from the bottom of the dip stick plug to fluid level, (inches)*	Volume (Gallons)	Distance from the bottom of the dip stick plug to fluid level (centimeters)	Volume (L)
66.3	100	168.4	378.5
62.5	150	158.8	567.8
58.6	200	148.8	757.1
54.8	250	139.2	946.4
50.9	300	129.3	1135.6
47.1	350	119.6	1324.9
43.2	400	109.7	1514.2
39.4	450	100.1	1703.4
35.5	500	90.2	1892.7
31.7	550	80.5	2082.0
27.8	600	70.6	2271.2
24.0	650	61.0	2460.5
19.1	700	48.5	2649.8
14.3	750	36.3	2839.1
10.1	800	25.7	3028.3

**Table 14:** Emulsion tank volume based on dipstick reading, for large dual 800-gallon in-hopper tanks

Distance from the bottom of the dip stick plug to fluid level, (inches)*	Fill volume (Gallons)	Distance from the bottom of the dip stick plug to fluid level (centimeters)	Fill volume (Liters)
42 5/8	25	108.3	94.6
39 5/8	50	100.7	189.3
36 3/8	75	92.4	283.9
33 3/4	100	85.7	378.5
31	125	78.7	473.2
28 3/8	150	72.1	567.8
26	175	66	662.4
23 3/8	200	59.4	757.1
20 7/8	225	53	851.7
18 1/2	250	47	946.4
16 1/2	275	41.9	1041.0
14 5/8	300	37.1	1135.6
12 5/8	325	32.1	1230.3
10 3/4	350	27.3	1324.9
8 3/4	375	22.2	1419.5
6 7/8	400	17.5	1514.2
4 3/4	425	12.1	1608.8

**Table 15:** Emulsion tank volume based on dipstick reading, for 450-gallon deck tanks.



Distance from the bottom of the dip stick plug to fluid level, (inches)*	Fill volume (Gallons)	Distance from the bottom of the dip stuck plug to fluid level (centimeters)	Fill volume (Liters)
47	25	119.4	94.6
44	50	111.8	189.3
40 1/2	75	102.9	283.9
37 3/4	100	95.9	378.5
34 3/4	125	88.3	473.2
31 1/2	150	80.0	567.8
28 3/4	175	73.0	662.4
25	200	63.5	757.1
21 3/4	225	55.2	851.7
18 1/2	250	47.0	946.4
14 3/4	275	37.5	1041.0
11 1/4	300	28.6	1135.6
7 3/4	325	19.7	1230.3
4 3/4	339	12.1	1283.3

**Table 16:** Emulsion tank volume based on dipstick reading, for 340-gallon in-hopper tanks.

Distance from the bottom of the dipstick plug to fluid level, (inches)*	Fill volume (Gallons)	Distance from the bottom of the dipstick plug to fluid level (centimeters)	Fill volume (Liters)
35	25	88.9	94.6
30 1/2	50	77.5	189.3
26	75	66.0	283.9
21	100	53.3	378.5
16	125	40.6	473.2
11 1/2	150	29.2	567.8
6 3/4	175	17.1	662.4
3	197	7.6	745.7

**Table 17:** Emulsion tank volume based on dipstick reading, for 200-gallon deck tanks.

\*Measure the fluid level with the dipstick placed in the bore, but do not thread the dipstick into the bore.



# Integral dx

121 N 1<sup>st</sup> Street

Montevideo, MN 56265 USA

T: 320.269.3227

[www.spraypaver.com](http://www.spraypaver.com)

[www.integraldx.com](http://www.integraldx.com)

[sales@integraldx.com](mailto:sales@integraldx.com)